

# OPERATING INSTRUCTIONS FOR

# **novopress**

## HYDRAULIC DRIVE SYSTEMS HA1ES / HA2

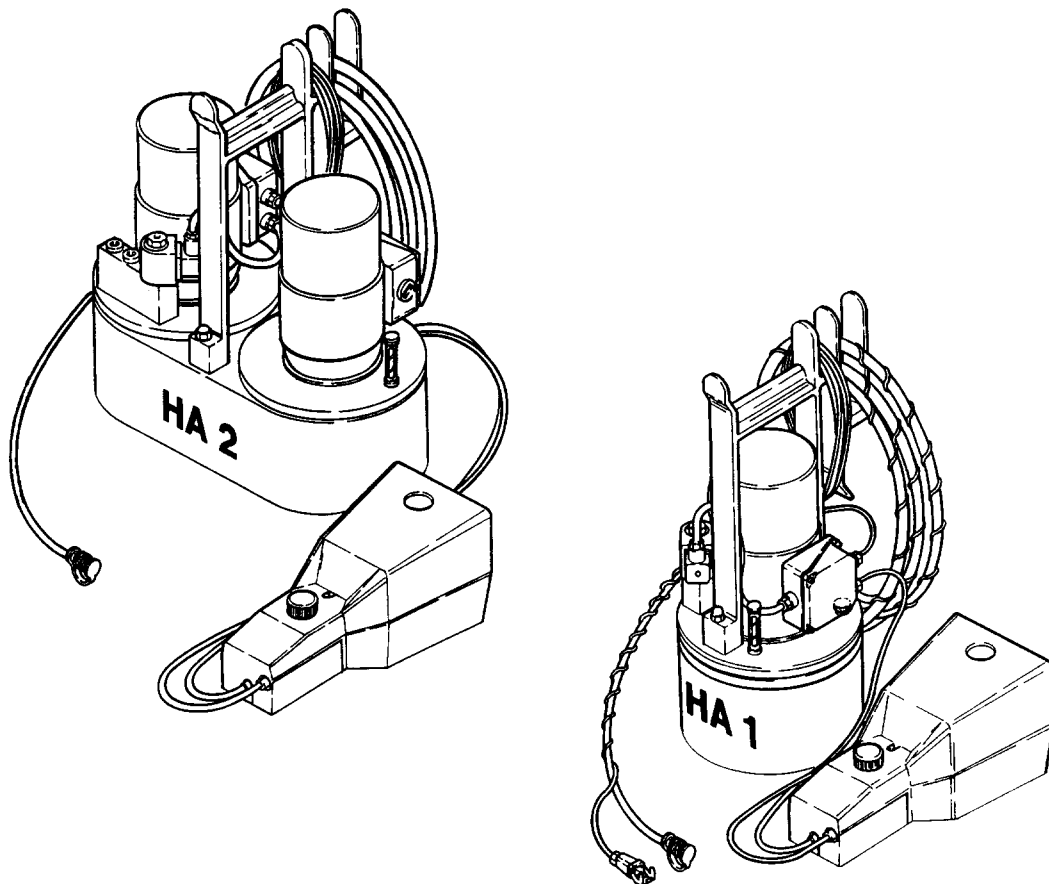

## Table of contents

	<b>Page</b>
CE Conformity Declaration	
Safety regulations	
Technical data	1
Intended use	2
Construction	2
Connecting system tools	3
Three-phase safety pedal switch	4
Operation	5
Maintenance	6
Appendix: - Circuit diagram	
- Hydraulics diagram	

## CE - KONFORMITÄTSERKLÄRUNG

entsprechend EG-Maschinenrichtlinie 98/37/EG, Anhang II A

Novopress GmbH & Co KG  
Scharnhorststr. 1  
D-41460 Neuss

Hydr. Antriebsaggregat

HA1ES	HA2
-------	-----

Ser-nr: .....

1. EN 292, EN 294, EN 349, EN ISO 9001, EN 60947-1, EN 60947-4-1
2. UVV VBG1, UVV VBG4, UVV VBG5, VDE 0100, VDE 0106

Hiermit erklären wir, daß die nachfolgend bezeichnete Maschine aufgrund Ihrer Konzipierung und Bauart sowie der von uns in Verkehr gebrachten Ausführung den einschlägigen grundlegenden Sicherheits- und Gesundheitsanforderungen entspricht.  
Bei einer nicht bestimmungsgemäßen Anwendung der Maschine oder bei einer nicht mit uns abgestimmten Änderung der Maschine verliert diese Erklärung ihre Gültigkeit.

**Angewandte harmonisierte Normen, insbesondere:**

siehe Punkt 1

**Angewandte nationale Normen, insbesondere:**

siehe Punkt 2

We hereby declare that with respect to its design and construction the machine stated below and the model thereof which we have brought into circulation conform with the applicable basic requirements on health and safety.

Any use of the machine other than that for which it is intended and any modification made thereto without our consent shall render this declaration null and void.

**Applied harmonized standards, in particular:**

see Item 1 above

**Applied national standards, in particular:**

see Item 2 above

Nous déclarons par la présente que par sa conception et son type ainsi que par l'exécution que nous avons mise sur le marché, la machine désignée ci-après répond aux exigences de sécurité et de prévention de la santé applicables.

La présente déclaration perd sa validité si la machine n'est pas utilisée conformément aux instructions ou dans le cas d'une modification de la machine à laquelle nous n'avons pas donné notre accord.

**Normes harmonisées utilisées, en particulier :**

voir point 1

**Normes nationales utilisées, en particulier :**

voir point 2

Hiermede verklaren wij, dat de hierna genoemde machine op grond van haar constructie en type alsmede de door ons in de handel gebrachte uitvoering aan de desbetreffende fundamentele eisen ten aanzien van de veiligheid en de gezondheid voldoet.

Wordt de machine niet overeenkomstig haar bestemming gebruikt of worden hieraan niet met ons overeengekomen wijzigingen aangebracht, dan verliest deze verklaring haar geldigheid.

**Toegepaste geharmoniseerde normen, in het bijzonder:**

zie punt 1

**Toegepaste nationale normen, in het bijzonder:**

zie punt 2

Datum / Herstellerunterschrift: 01.04.04

Angaben zum Unterzeichner:

  
Geschäftsführer

Con la presente declaramos que la máquina denominada a continuación, por su concepto y por su construcción, cumple con los requisitos fundamentales de seguridad y sanidad en vigor. Lo dicho aplica exclusivamente a la máquina en su versión original, tal y cual ha sido fabricada por nosotros.

El empleo inapropiado de la misma, así como cualquier modificación ejecutada sin nuestra intervención hace que esta declaración pierda su validez.

**Normas armonizadas aplicadas, en particular:**

véase bajo el punto 1

**Normas nacionales aplicadas, en particular:**

véase bajo el punto 2.

Si dichiara che la macchina appresso descritta soddisfa, per concetto, tipo e modello messo in commercio, le esigenze di base di sicurezza e sanità relative a tali apparecchiature.

In caso di uso non appropriato della macchina o in caso di una sua modifica eseguita senza il nostro accordo, questa dichiarazione non ha più effetto.

**Norme armonizzate applicate, in particolare**

vedi punto 1

**Norme nazionali applicate, in particolare**

vedi punto 2

Härmed försäkrar vi att nedan nämnd maskin motsvarar de tillämpliga och principiella säkerhets- och hälsoföreskrifterna både gällande koncipieringen och konstruktionen samt gällande den av oss sålda modellen.

Används denna maskin inte enligt anvisningarna eller förändras maskinen på ett sätt som vi inte har godkänt, gäller denna försäkran ej.

**Tillämpade harmoniserade normer, i synnerhet:**

se punkt 1

**Tillämpade nationella normer, i synnerhet:**

se punkt 2

Täten vakuutamme, että seuraavassa nimetty kone vastaa suunnittelunsa, rakenteensa sekä meidän taholtamme liikenteeseen päästetyn mallinsa puolesta asiaankuuluvia perustavaa laatua olevia turvallisuus- ja terveysmääräyksiä.

Jos konetta ei käytetä määräysten mukaisesti tai jos koneeseen tehdään muutos ilman meidän suostumustamme ei tämä selvitys enää päde.

**Käytetyt harmonisoidut standardit, varsinkin:**

katso Kohta 1

**Käytetyt kansalliset standardit, varsinkin:**

katso Kohta 2

Herved erklærer vi at den i det følgende betegnede maskinen på grunn av dens konsipering og konstruksjon samt utførelsen som vi har brakt på markedet tilsvare de respektive grunnleggende krav til sikkerhet og helse.

Ved en bruk av maskinen som ikke er formålstjenlig eller ved en endring av maskinen som ikke er avstemt med oss mister denne erklæringen sin gyldighet.

**Benyttede harmoniserte standarder, særlig:**

se punkt 1

**Benyttede nasjonale standarder, særlig:**

se punkt 2

Declaramos pelo presente, que a máquina a seguir designada, na sua planificação e construção, assim como no modelo por nós comercializado, obedece às respectivas exigências fundamentais de segurança e de saúde.

A presente declaração perde a validade em caso de uso impróprio da máquina ou em caso de modificações na máquina, que não tenham sido acordadas antecipadamente connosco.

**Normas harmonizadas aplicadas, especialmente:**

vide parágrafo 1

**Normas nacionais aplicadas, especialmente:**

vide parágrafo 2

## **GENERAL SAFETY REGULATIONS**

### **Read all safety regulations and instructions!**

1. Keep the place of work clean.  
Disorderly work-places and work-benches invite accidents.  
Ensure that lighting is good.
2. Keep children away.  
Do not allow unauthorised persons to touch the device or the cable.  
Keep unauthorised persons away from your place of work.
3. Wear suitable working clothing.  
Do not wear any wide clothes nor jewellery - they may get caught up in moving parts.  
When working in the open it is recommended that you wear rubber gloves and non-slip footwear. Wear a hair- net if you have long hair.
4. Always be alert.  
Only use a device after having been instructed in its operation.  
Concentrate on your work. Proceed sensibly.  
Do not use the device when you are distracted.
5. Do not lean too far forward. Avoid abnormal stance.  
Make sure that you have a secure standing position, and maintain balance at all times.
6. Leave safety devices where they belong.
7. Hand tools may not be installed as fixtures.
8. Repair and maintenance.  
Have repairs and maintenance work carried out in an authorised NOVOPRESS specialist workshop.  
Only use original and identical NOVOPRESS spare parts.  
We reject all responsibility and liability for work carried out by third- party personnel.

## SAFETY INSTRUCTIONS FOR HYDRAULIC EQUIPMENT

1. Please read the operating instructions.  
Acquaint yourself with the hydraulic equipment.
2. Provide the equipment with the necessary care.  
Always keep the equipment in operational condition.  
Cleanness is an essential requirement for good and safe working.
3. Switch off the electric power supply to the hydraulic equipment,
  - when the equipment is not in use
  - when maintenance work is to be carried out.
4. Avoid unintentional switching - on.  
Keep hands and feet away from the switch when the equipment is not being used.
5. Do not use the equipment in a manner in contravention of the instructions.  
Never carry the equipment by the pipe or pull on the pipe.  
Protect the piping from heat, oil, sharp edges and high levels of weight strain.
6. Use only piping, fittings and accessories which have been designed for the operating pressure of the hydraulic unit.  
**BURSTING PRESSURE OR TEST PRESSURE IS NOT OPERATING PRESSURE!**  
Avoid squashing or bending of the piping.  
Piping must not be painted over.
7. Replace the hydraulic piping
  - when cracks, squashed or bent points are to be seen
  - when blistering is established
  - when hydraulic fluid escapes
  - when pipe fittings are damaged
  - when discolouration is established on the outer layer, e.g. due to the influence of solvents.
8. The hydraulic fluid used in the system is kerosene-based.  
This requires particular care and attention.
  - Avoid continuous contact with the skin
  - ensure that the hydraulic fluid does not get into the eyes or mouth.Hydraulic pipes have to be replaced after 5 years of usage, despite of the circumstance that no damages should be remarkable.
9. The equipment must not be operated, if it has leaks and there is a danger of hydraulic fluid coming into contact with persons, open fire, heating equipment, electric cabling, ground water, foods and other substances which are intended for human consumption.
10. Hydraulic units with petrol engines
  - must not be operated in closed rooms, due to the **DANGER OF INTOXICATION!**
  - do not pour in petrol while the motor is running or in the vicinity of open fire. **DANGER OF EXPLOSION!**

## SAFETY TIPS FOR ELECTRIC TOOLS

**ATTENTION: In order to avoid electric shock, danger of injury and burning the following basic safety measures are always to be taken when using electric tools. Read and observe the notes before using the device. Keep the safety tips in a safe place.**

1. Take influences of the surroundings into account.  
Do not expose electric devices to rain.  
Do not use electric devices in damp or wet surroundings.  
Do not use electric devices in the vicinity of flammable liquids or gases.
2. Protect yourself from electric shock.  
Do not fix additional rating plates or symbols with rivets or screws.  
Use adhesive signs. When working with electric devices avoid body contact with earthed objects such as pipes, heating appliances, refrigerators etc.
3. Use the correct tools.  
Only use the tools and accessories outlined in the operating instructions.  
Do not use the electric device to do work for which it is not intended.
4. Secure the work piece.  
Use gripping devices or vice grips to hold the work piece steady.  
It is more securely held than by hand and you can operate the device with two hands.
5. Do not overload your electric device.  
You can work better and more securely in the indicated power range.
6. Do not use the cable for purposes for which it is not intended.  
Do not carry the electric device by the cable.  
Do not use the cable in order to pull the plug out of the socket. Protect the cable from heat, oil, acids and sharp edges.  
For working in wet rooms or in the open only use the authorised extension cables with the corresponding marking.
7. Avoid unintentional starting.  
Ensure that the electric device is switched off before connecting the mains plug.  
Do not carry the electric device in such a way as that your finger is on the switch.  
Do not use the electric device if the ON/OFF switch does not work perfectly.
8. Disconnect the mains plug:
  - if the device is not in use
  - before maintenance of the electric device
  - when changing tools
9. Carefully maintain the electric device. The best and most secure work is guaranteed if you:
  - keep the electric device clean
  - observe the instructions for greasing, changing the tools and ancillary equipment
  - regularly check the connection cable and the extension cable
  - have damaged cables repaired by a specialist
  - keep hand grips dry, clean and free from oil and fat
  - have the electric device examined and cleaned by a specialist after 900 operating hours.

10. Keep electric devices in a safe place.  
Store electric tools and accessories out of the reach of children, in dry, high-lying places or in locked rooms.
11. Electric devices are often used by more than one person. Therefore before beginning to work you should check:
  - the socket to ensure it is securely fixed and is not damaged in such a way as can be seen from the outside
  - the connection cable for outward damage to the insulation and for sharp kinks
  - that the cable is securely fixed to the device and whether the insulating plastic tube is damaged
  - that the switch is secure and shows no outward signs of damage
  - whether protective appliances or damaged parts function properly
  - whether movable parts jam or are damaged
  - do not use the device in the event of finding defects
  - only allow the device to be repaired by a specialist or in an authorised NOVOPRESS specialist work-shop
  - only use original and identical NOVOPRESS spare parts.



## Technical data

### Electric motor:

Connection voltage:	See identification plate
Power consumption:	800 W
Rotational speed:	max. 10000 min <sup>-1</sup>
Mode of operation:	S 3; 25 % 100 s
Protection class:	1
Mode of protection:	IP - 44
Radio interference:	As per VDE 0875
Power connection:	Cable, 5 m long, with a three-phase safety pedal switch and earthing contact-type plug

### Hydraulics:

Hydraulic connection:	Quick-action coupling plug with back-pressure valve		
Operating pressure:	150 bars max.		
Delivery capacity:	at n = 1000 min <sup>-1</sup> :	HA 1 = 0.45 l/min	HA 2 = 0,9 l/min
Dimensions:	HA 1 ES:	H = 470 mm; B = 250 mm;	L = 280 mm
	HA 2:	H = 470 mm; B = 280 mm;	L = 460 mm
Weight incl. oil:	HA 1 ES:	18 kg	
	HA 2:	34 kg	
Hydraulic oil:	Oil filled in at works: ISO VG 10 DIN 51519 (suitable for external temperatures from -5 to +35 °C)		
	Oil usable: Oil in viscosity class: ISO VG DIN 51519 from 10 to 46 (viscosity in CSt 7.4 - 30 at 50 °C)		
	Oil for temperatures < - 5 °C: ISO VG 5 DIN 51519		

## Hydraulic control units (basic equipment)

With respect to the hydraulic control units there are the following versions:

- |    |         |                 |   |
|----|---------|-----------------|---|
| 1. | HA 1 ES | Order No. 31070 | Hydraulic control unit with 1 electric motor  |
| 2. | HA 2    | Order No. 31375 | Hydraulic control unit with 2 electric motors |

### Intended use

NOVOPRESS hydraulic control units operate in the low-pressure range up to 150 bars, and they are used as drive units for our hydraulic system tools.

The hydraulic unit may only be used with Novopress system tools which have been approved for this unit (see operating manual for the system tool).

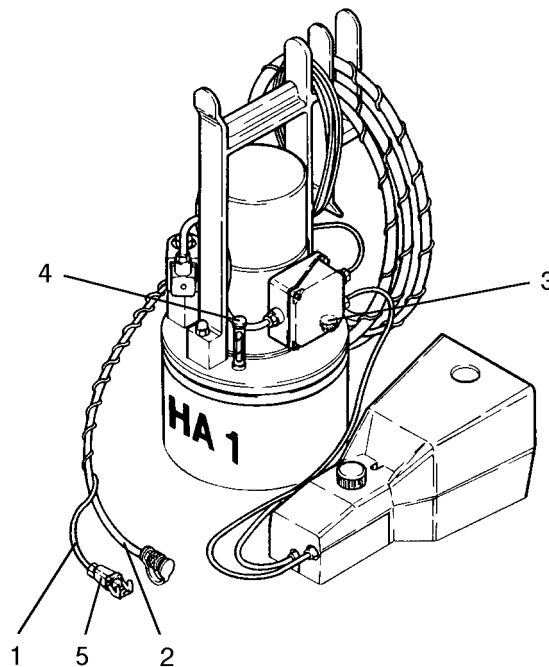

### Construction

An oil-filling screw with breather valve (3) and an oil gauge (4) are mounted on the oil tank cover.

#### Oil gauge (4):

The gauge stick of the oil gauge must be between the two markings. If the gauge stick is at the lowest marking, oil needs to be added.

#### Bleeding valve (3):

The air-relief valve closes if the tank is on the slant (no oil can emerge).

In the vertical position (operating position), a slight amount of oil vapour may be carried over with the escaping air. The oil film which this causes on hydraulic equipment should be removed from time to time.

#### Note:

*The equipment **must not** be switched on while horizontal. There is a risk that the pump will not draw in oil and is damaged as a result.*

## Connecting system tools

The system tools are connected to the hydraulic control unit by means of the control line (1) and the hydraulic hose (2), using the quick-action coupling.

### Connecting the hydraulic line

#### Quick-action coupling

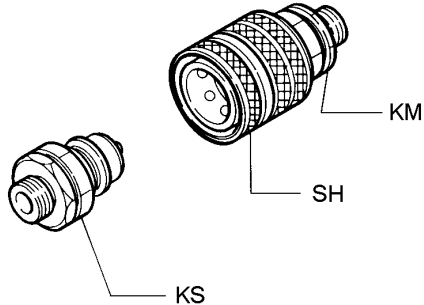

#### Coupling-up

Hold the coupling socket (KM) up to the sliding sleeve (SH), and slide it onto the coupling plug (KS).

#### Uncoupling

Hold the coupling socket (KM) at the sliding sleeve (SH) and pull it off the coupling plug (KS).

#### Note:

- When changing the system tools, a small amount of oil will remain between the back-pressure valves of the coupling.
- Handle the hydraulic hose with care. Bends at the connection points will lead to premature breakdown. When coupling up, make sure that dirt does not penetrate the coupling.
- Before coupling up another system tool, wipe out the coupling socket with a clean cloth - that is free of fluff.
- The system tools should, as far as possible, remain coupled up at all times.

## Connecting electrical leads

### HA 1 ES

- Connect the control line (1) of the hydraulic control unit (HA 1 ES) to the system tool with the aid of the plug connector (5).

### HA 1 ES + HA 2

- Connect the mains cable to the power supply line.

#### Note:

*Observe the mains voltage (see identification plate)!*

## Three-phase safety pedal switch

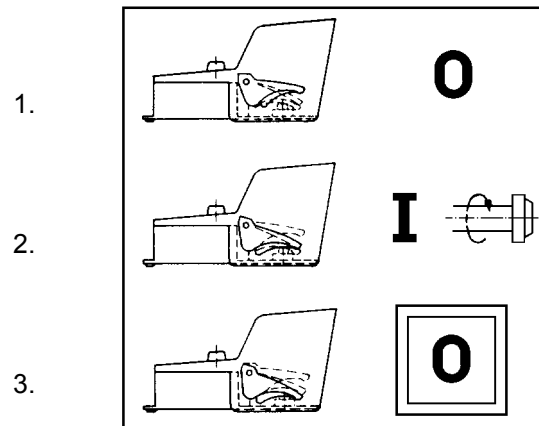

1. Pedal not actuated
2. Pedal actuated as far as detectable stop of pressure point
3. Pedal actuated beyond pressure point

System tool **"OFF"**

System tool **"ON"**

**"EMERGENCY OFF"**  
Pedal switch locked.

### Note!

When EMERGENCY OFF is actuated:

- The hydraulic control unit is switched off and cannot be restarted by pressing the pedal again.
- To release the system, press the blue pushbutton (6).

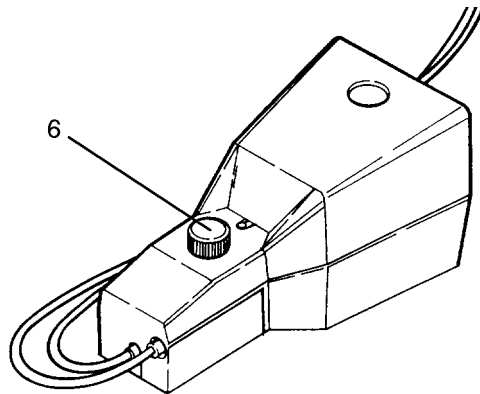

## Operation

**Note!**

- *The hydraulic unit can only be actuated with the manual button (located on the system tool), or by the pedal switch.  
The system tool which is connected will determine how the hydraulic device has to be operated.  
When the manual key is actuated, the EMERGENCY OFF function of the pedal switch is active.*
- *The equipment **must not** be switched on while horizontal. There is a risk that the pump will not draw in oil and is damaged as a result.*

- Actuate the manual key or pedal switch, and hold it down.

**Note!**

*When the manual or pedal switch is released, the piston of the system tool will return immediately.*

- The piston of the connected system tool will travel forwards.  
The system tool is "working".
- Once the work process has been completed or the safety valve has responded, release the manual key or the pedal switch immediately. Otherwise the oil will heat up unnecessarily.

**Note!**

- *Care should be taken to ensure that the oil temperature does not exceed 70 °C during operation.*
- *Pressure can only be built up again once the key has been released and actuated again.*

## Maintenance

We recommend that our authorized NOVOPRESS specialist workshops be used for repair and maintenance work.

Only have the equipment maintained by a specialist.

**Caution!** BEFORE ANY MAINTENANCE OR REPAIR WORK,  
**ALWAYS PULL OUT THE MAINS PLUG!**

### Check oil level

The gauge stick of the oil level indicator (4) must be between the two markings. If it is at the lowest marking, oil must be added. Top up the oil if necessary.

### Oil change

First oil change: After about 1,000 starts, or after 3 months

Other oil changes: After every 15,000 starts, but at least once annually

Oil volume for:	HA1 ES	3.5 litres
	HA 2	6.5 litres

Hydraulic oil: See Technical Data

Oil filter: The oil filter is the suction strainer with a mesh width of 0.06 mm.

- Unscrew the oil filling screw with the air-relief valve (3) on the oil tank cover.
- Draw off the old oil by means of suction.
- Fill with new oil.

**Note!**

*The gauge stick of the oil level oil gauge (4) must be between the two markings.*

**Cleaning:** Remove the oil film from the hydraulic unit every month.

**Hydraulic hose:** The hydraulic hose is to be checked for damage every month.

Replace hydraulic hose:

- If any cracks, crush points, or kinks are visible on the outer layer
- If blister formation is visible
- If pressurised fluid is escaping
- If the hose armature is damaged
- If any discolouration of the outer layer is visible, e.g. due to the effect of solvents.

Hydraulic hoses must be replaced after 5 years, even if no damage is visible.

### Visual and electrical inspection

Regularly: Check mains cable including plug and extension cord with plug connectors for visible damage and have repaired, if necessary.

Every 6 months: Have an inspection complying with DIN VDE 0701-1 and DIN VDE 0702 for electric devices of the protection class 1 carried out by a qualified technician, an authorized workshop or Novopress Neuss.

### Hydraulic drive unit H A 1 E S

Legend:

- 1 = Control line
- 2 = Hydraulic hose
- 3 = Air-relief valve
- 4 = Oil gauge
- 5 = Plug-in connector
- 6 = Pushbutton
- 7 = Pedal switch

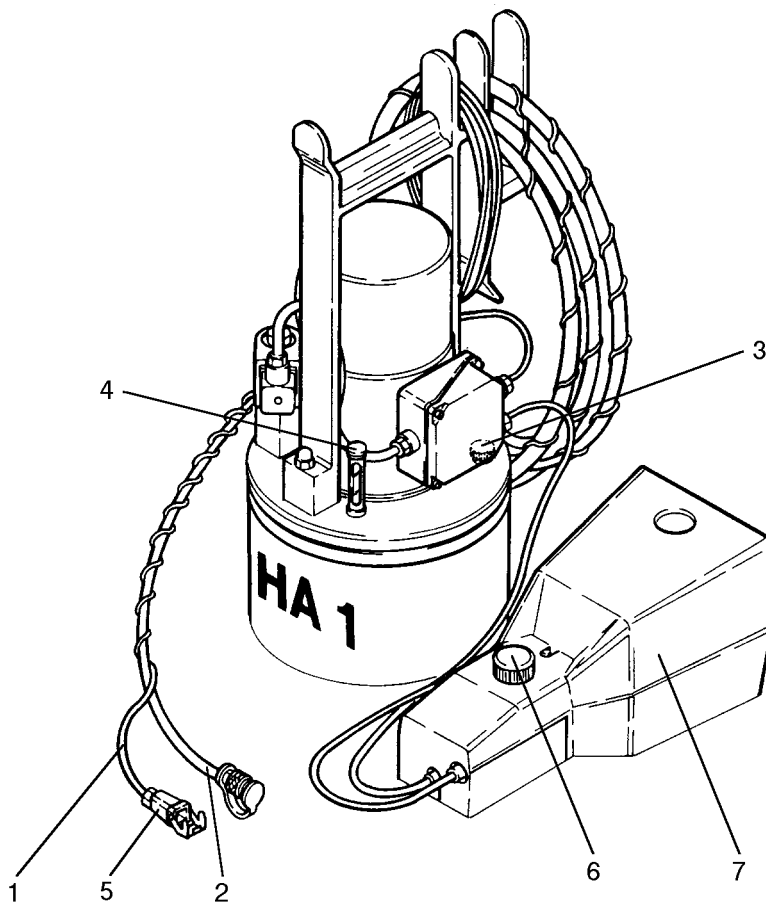

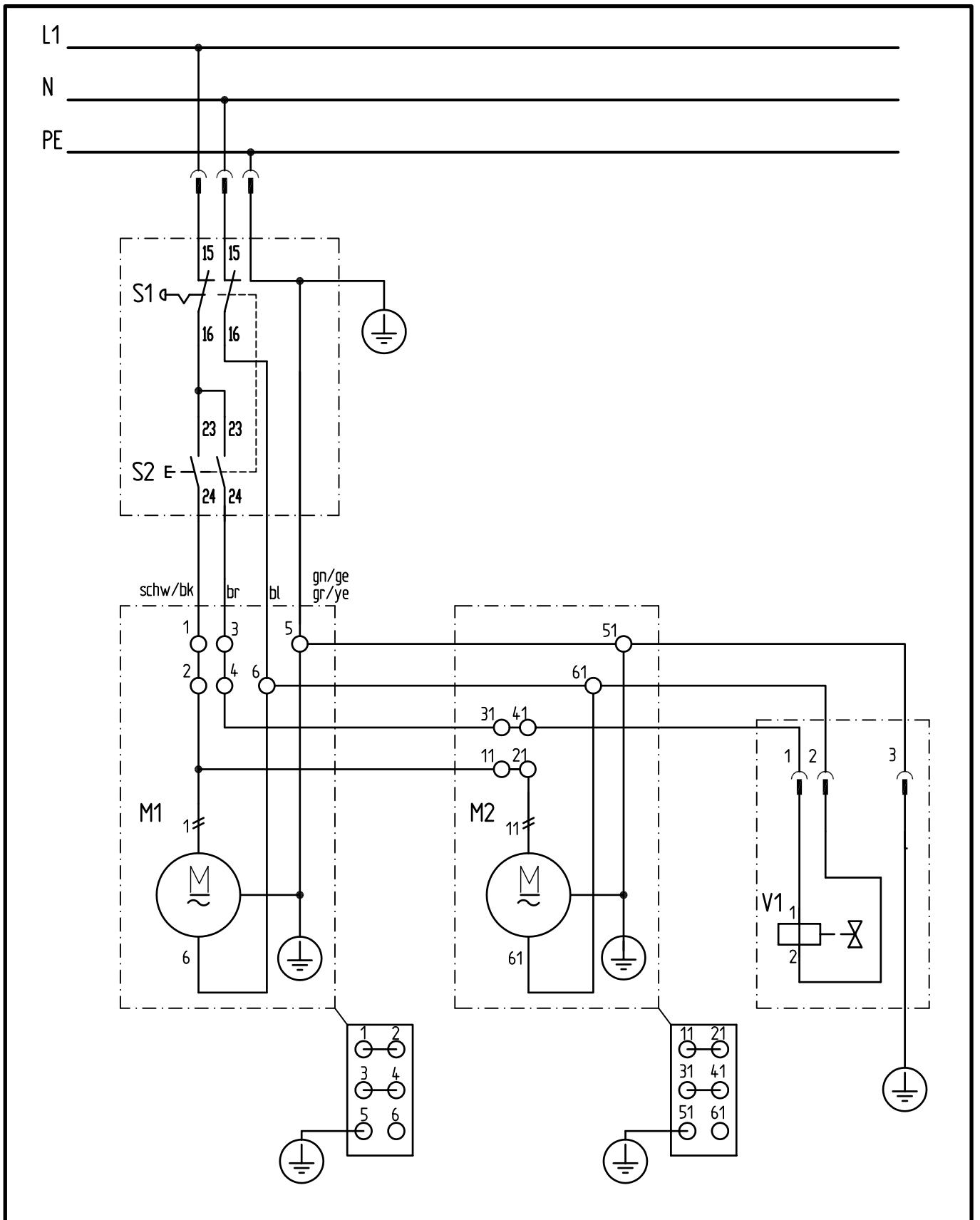

Tolerierung ISO 8015		Allg.-Toleranzen		Oberflächen		Maßstab		Gewicht	
Änderungen nur über CAD		ISO 2768-		Reihe 2		Werkstoff/Halbzeug:		kg	
Schutzvermerk nach DIN 34 beachten		mK		DIN 3141		—		—	
		1995	Datum	Name		Benennung: <b>Stromlaufplan</b> HA2			
		Bearb.	06.04.	Scholz					
		Gepr.	06.04.	Nghiem					
		Norm							
		<b>novopress</b>		Sach-Nr.		<b>31971.4</b>		Blatt	
		Neuss		CAD-Nr.:		31375\31971j01		1	
Zust.	?M-Nr.	Datum	Name	Ursprung	Ersatz für	Ersetzt durch		2 Blätter	



S1	Not-Aus Taster
S2	Fußtritttaster
M1	Motor
M2	Motor
V1	Ventil

S1	emergency stop
S2	foot switch
M1	motor
M2	motor
V1	valve

Tolerierung ISO 8015		Allg.-Toleranzen		Oberflächen		Maßstab		Gewicht	
Änderungen nur über CAD		ISO 2768-mK		Reihe 2		Werkstoff/Halbzeug:		kg	
Schutzvermerk nach DIN 34 beachten				DIN 3141					
			1995	Datum	Name	Benennung: <b>Stromlaufplan</b> HA2			
			Bearb.	06.04.	Scholz				
			Gepr.	06.04.	<i>Nghiem</i>				
			Norm						
			 <b>novopress</b> Neuss			Sach-Nr. <b>31971.4</b>		Blatt 2	
						CAD-Nr.: 31375\31971j01		2 Blätter	
Zust.	ÄM-Nr.	Datum	Name	Ursprung	Ersatz für		Ersetzt durch		

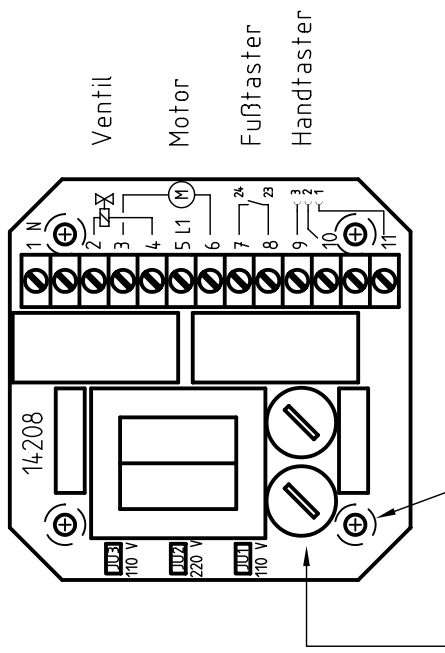
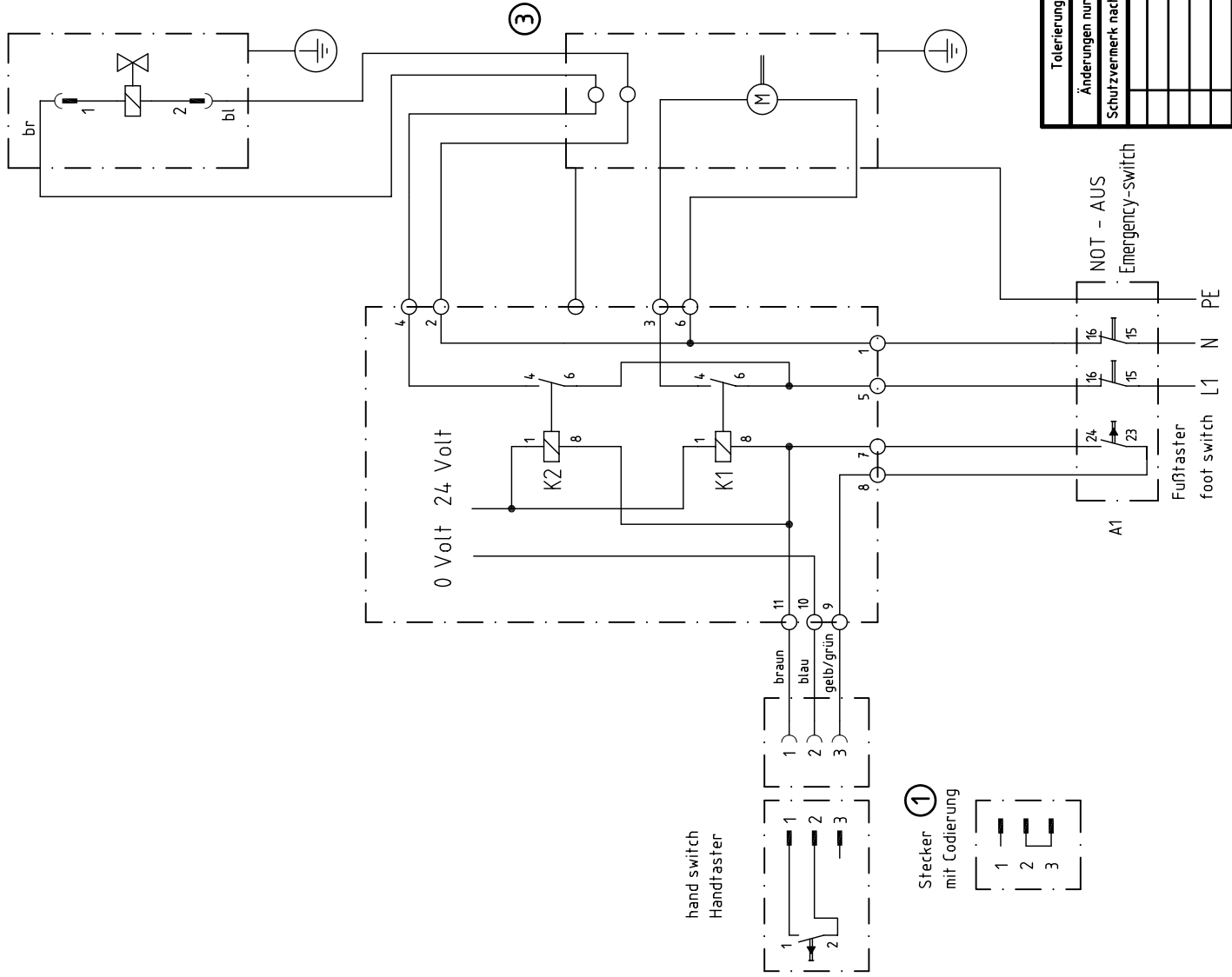

PE über Platine und Abstandsbolzen zum Motor

je T 0,1A ②

Tolerierung ISO 8015		Allg.-Toleranzen ISO 2768- mK		Oberflächen Reihe 2 DIN 3141		Maßstab 1:1		Gewicht kg	
Änderungen nur über CAD		Schutzvermerk nach DIN 34 beachten		Name		Benennung: <b>HA 1 220 Volt mit Fußschalter und Steuerkabel</b>		Sach-Nr. <b>31070J05.3</b>	
3 31070x06.doc		220198		Hö		Bearb. 28.12.94		Beit 1	
2 Ergänzung		170795		Ke		Gepr. 28.12.94		CAD-Nr. S.A.31070A.31070J06	
1 Ergänzung		250195		Ke		Norm		Ersatz für	
Zust.		Äh-Nr.		Name		Ursprung		Ersatz durch	
		Datum		Neuss		NOVOpress			

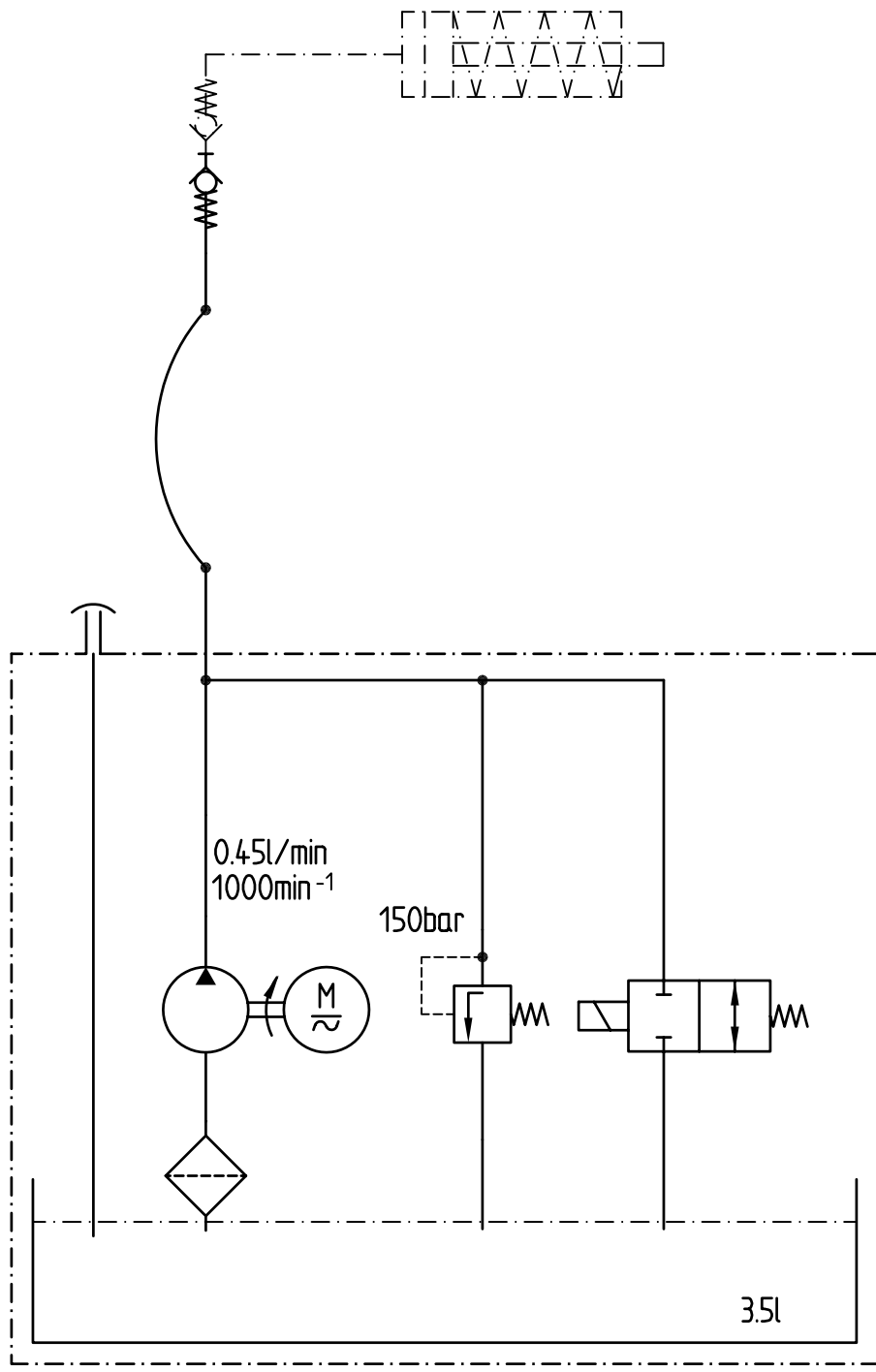

Tolerierung ISO 8015		Allg.-Toleranzen		Oberflächen		Maßstab		Gewicht	
Änderungen nur über CAD		ISO 2768-mK		Reihe 2		Werkstoff/Halbzeug:		kg	
Schutzvermerk nach DIN 34 beachten				DIN 3141					
		1994	Datum	Name		Benennung:			
		Bearb.	9.6.	Pfeiffer		<h1 style="text-align: center;">Hydraulikplan</h1> <h2 style="text-align: center;">HA1-ES , HA1-Bau</h2>			
		Gepr.	9.6.	Nghiem					
		Norm							
				Sach-Nr.		31505.4		Blatt	
				CAD-Nr.:		31070\31505J01.DWG		1	
Zust.	?M-Nr.	Datum	Name	Ursprung		Ersatz für		Ersetzt durch	

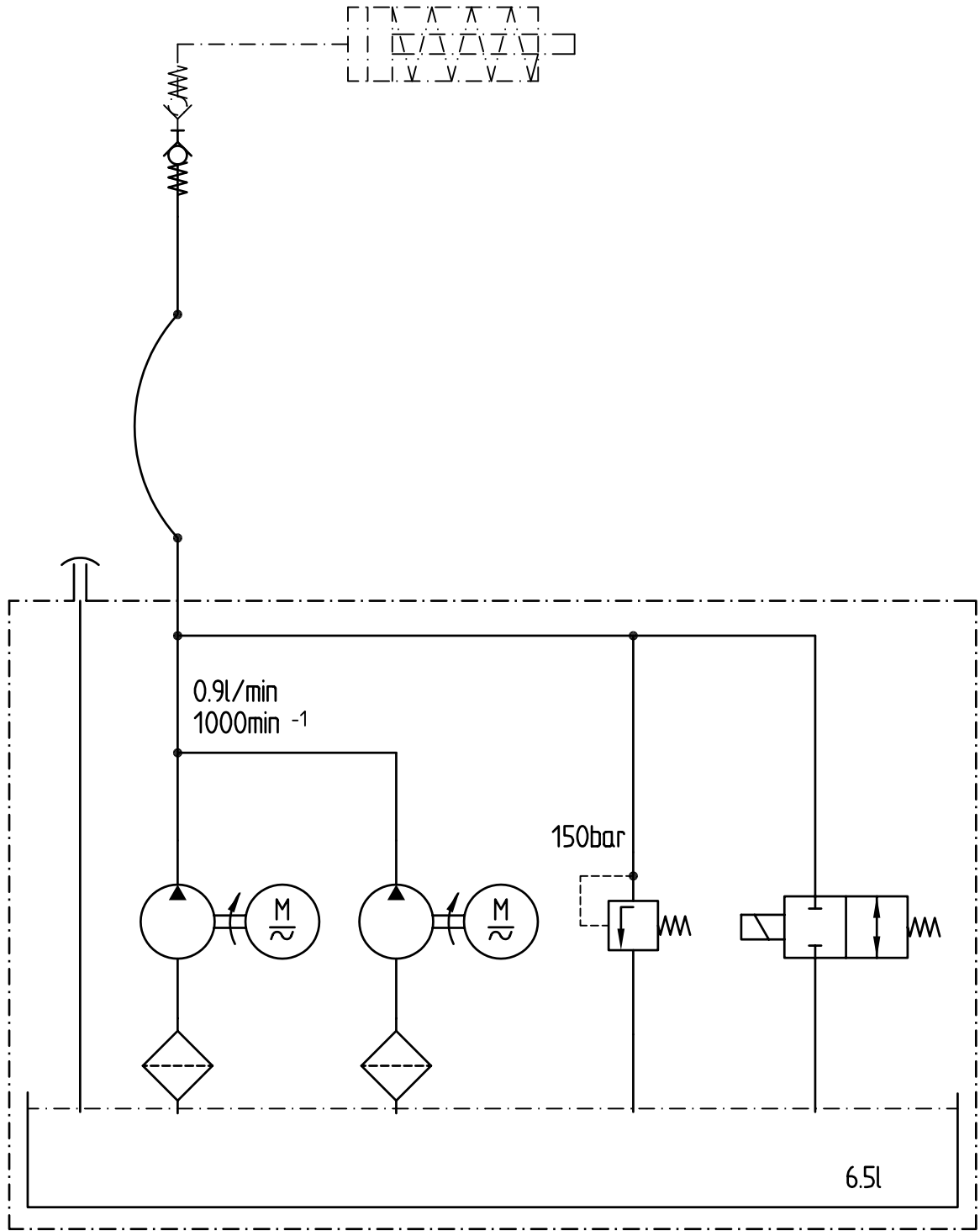

Tolerierung ISO 8015		Allg.-Toleranzen		Oberflächen		Maßstab		Gewicht	
Änderungen nur über CAD		ISO 2768-		Reihe 2		Werkstoff/Halbzeug:		kg	
Schutzvermerk nach DIN 34 beachten		mK		DIN 3141		—		—	
		1994	Datum	Name		Benennung:			
		Bearb.	9.6.	Pfeiffer		<h1 style="text-align: center;">Hydraulikplan</h1> <h2 style="text-align: center;">HA2</h2>			
		Gepr.	9.6.	Nghiem					
		Norm							
				Sach-Nr.		31507.4		Blatt	
		Neuss		CAD-Nr.:		31375\31507J01.DWG		1	
Zust.	ÄM-Nr.	Datum	Name	Ursprung		Ersatz für		Ersetzt durch	

Repairs / Service

**NOVOpress**

Scharnhorststraße 1  
D-41460 Neuss

PO Box 101163

D-41411 Neuss

Tel. 02131 / 2880

Federal Republic of Germany

Telefax 02131 / 28855