

InteliNano^{NT} MRS 3

Single small gen-set controller

Single small gen-set controller for prime-power applications



Operator Guide

TABLE OF CONTENTS

1	Operator Interface	2
2	Display Screens Structure	4
2.1	Main screens structure (CT not connected)	4
2.2	Main screens structure (CT connected)	5
3	Alarms, Events and History	7
3.1	Events	8
3.2	Warnings	8
3.3	Shutdowns	9
3.4	ECU Messages	10
4	Start and Stop engine	11
4.1	MANUAL mode	11
4.2	AUTO mode	11

Copyright © 2017 ComAp a.s.

ComAp, a.s.

U Uranie 1612/14a, Prague 7, Czech Republic

Tel: +420 246 012 111

E-mail: info@comap-control.com, www.comap-control.com

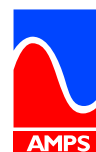

1 Operator Interface

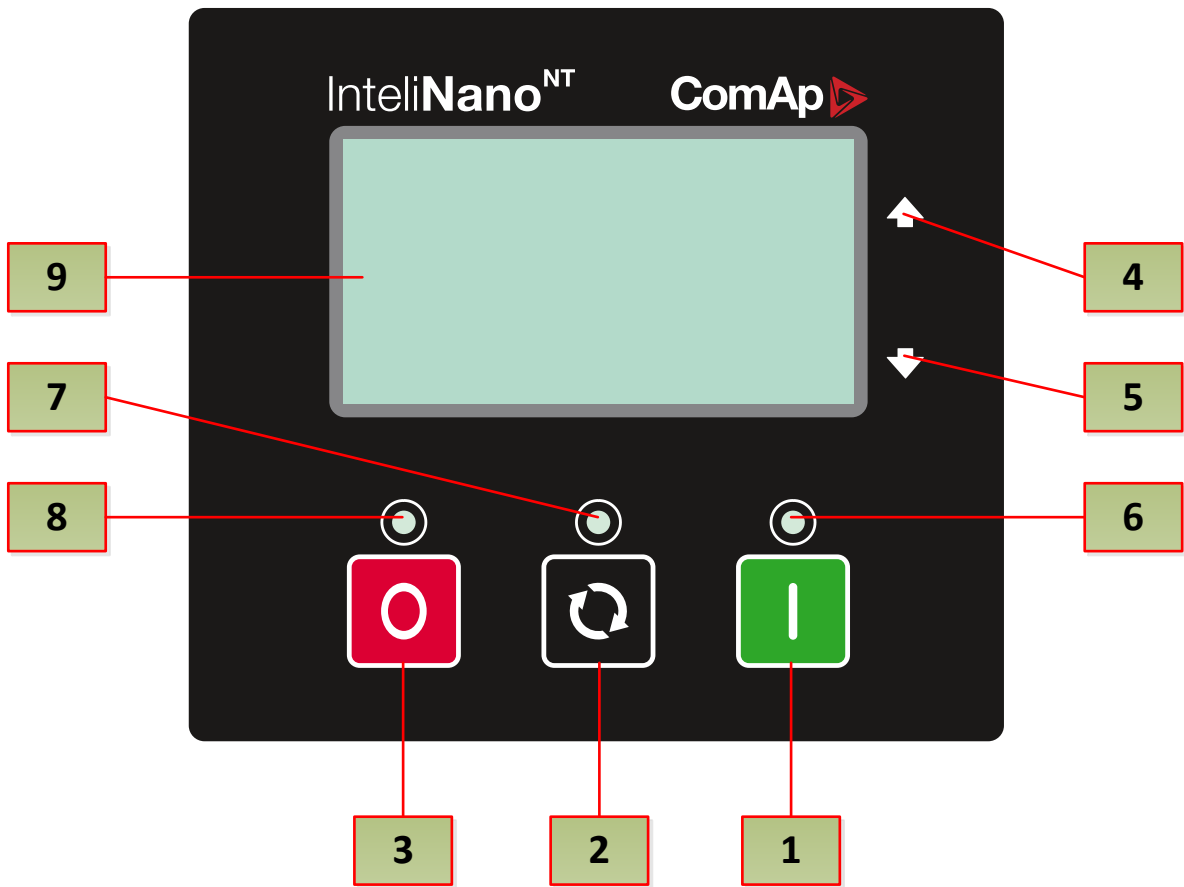

Figure 1.1

GEN-SET CONTROL BUTTONS		
Position	Button	Description
1		Start (START) button. Works in Manual mode only. Press this button to initiate the start sequence of the engine - in Manual operating mode only. This button is also used to confirm changes in setup mode.
2		Auto (AUTO) button is dedicated for switching between auto and manual operating mode.
3		Stop (STOP) button. Press this button to initiate the stop sequence of the gen-set when engine is running - in Manual operating mode only. This button is also used to cancel changes in setup mode, to go back or to exit and for alarm confirmation.
4		Up (▲) button for move up or value increasing.
5		Down (▼) button for move down or value decreasing.

GEN-SET OPERATION INDICATORS	
Position	Description
6	Engine operation. Green LED is blinking, if engine is starting, cooling or stopping. When LED is on the engine is running and is loaded or ready to load.
7	Operating mode. When the green LED is on, the controller is in Auto operating mode. When is off the controller is in Manual mode.
8	Alarm red LED. The LED will blink when there is one or more active warning or active shutdown alarm. The LED is on when the active shutdown alarm is confirmed and the engine can't be started.
9	Graphic B/W display, 128x64 pixels

2 Display Screens Structure

The displayed information is structured into "screens". Use ▲ and ▼ button to switch over the screens.

2.1 Main screens structure (CT not connected)

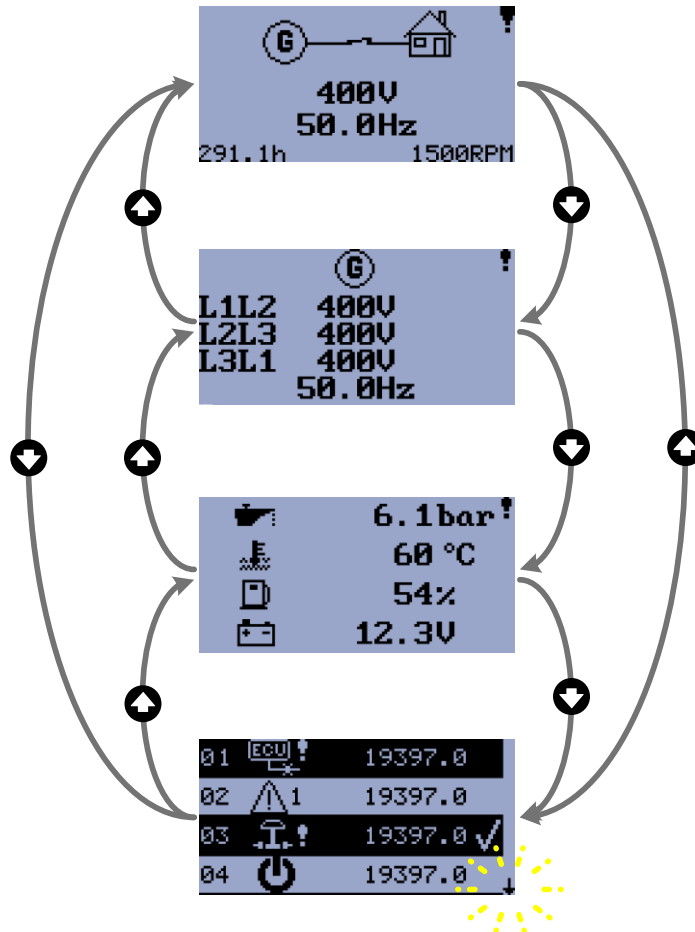

Figure 2.1

- First screen displays basic information about voltage and frequency measurement. There is also displayed position (status) of GCB, running hours counter and RPM information. When any alarm occurs the general alarm symbol will be displayed on the LCD's upper right corner.
- Second screen contains detailed voltage and frequency information.
- Third screen shows the senders information – oil pressure; coolant temperature; fuel level and battery voltage.
- Fourth screen shows latest alarms or events.

2.2 Main screens structure (CT connected)

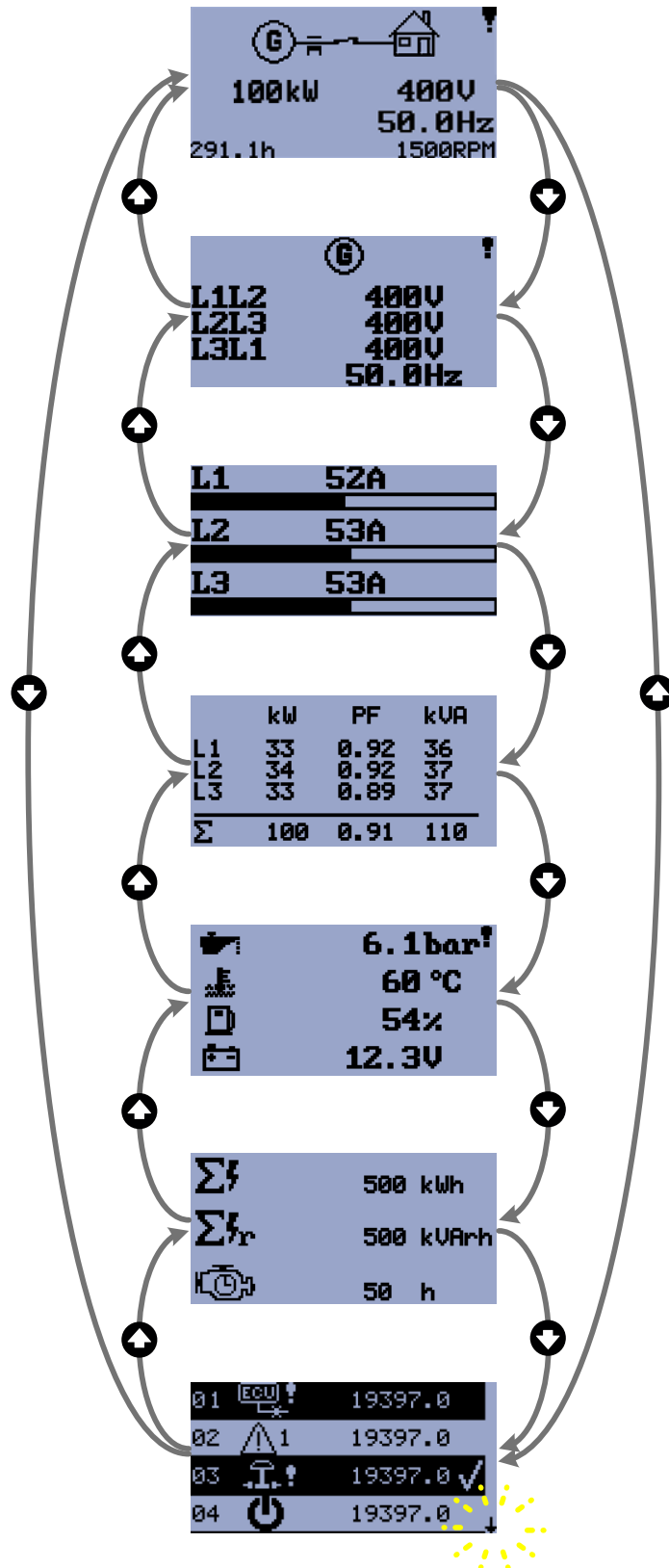

Figure 2.2

- First screen displays basic information about voltage, frequency and real power measurement. Icon depicting installed CT is displayed next to generator symbol. There is also displayed position (status) of GCB, running hours counter and RPM information. When any alarm occurs the general alarm symbol will be displayed on the LCD's upper right corner.
- Second screen contains detailed voltage and frequency information.
- Third screen shows measured current for individual phases. For each current bar-graph is shown.
- Fourth screen shows real and apparent power with power factor for individual phases and totals are also displayed.
- Fifth screen shows senders information – oil pressure; coolant temperature; fuel level and battery voltage.
- Sixth screen shows energy counters (real and reactive) and also running hours counter.
- Last screen shows latest alarms or events.

3 Alarms, Events and History

Following alarms and records are available:

- [Event](#)
- [Warnings](#)
- [Shutdowns](#)
- [ECU Messages](#)

Four records can be displayed simultaneously on the LCD screen. Total capacity is 15 records. The **Figure 3.1** is an example of how the history is organized. The last screen in this example is showing the four latest events.

To view further history records you have to wait 3 seconds till down arrow stops blink, then press **▼** button (see **Figure 3.2**). For alarm (shutdown) confirmation press **STOP** button.

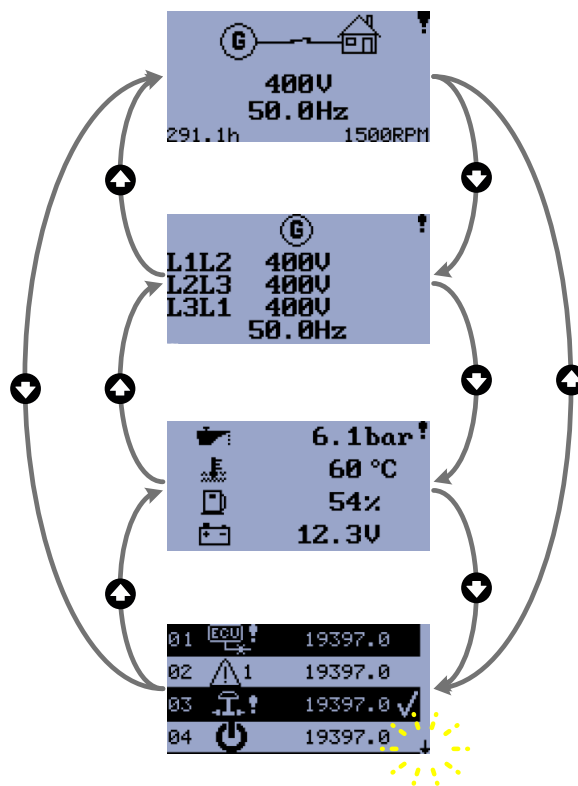

Figure 3.1

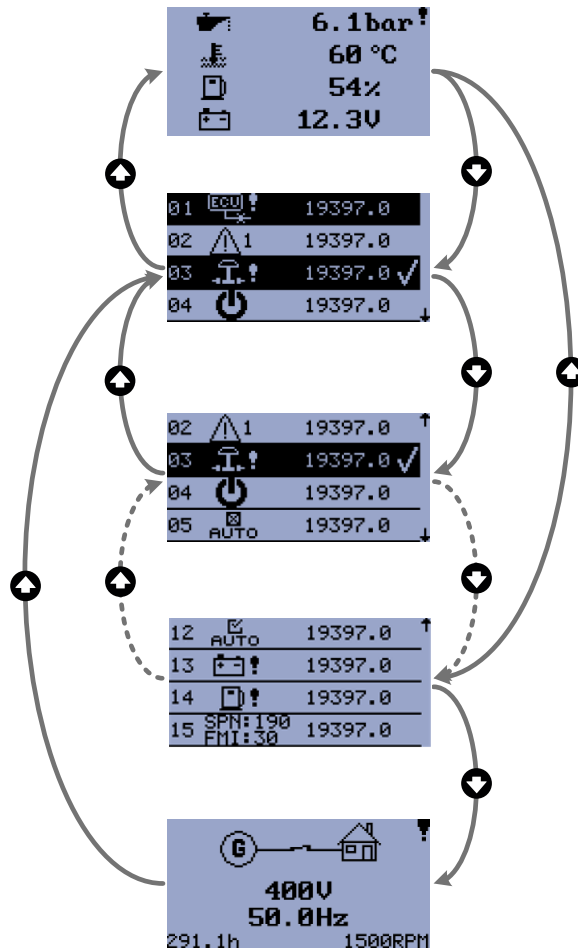

Figure 3.2

3.1 Events

Every event listed in table below is saved in history with running hours stamp see **Figure 3.3**.



Figure 3.3
event – Power On

3.2 Warnings

3.2.1 Active warning

When a warning occurs, **O04 Alarm** and **O15 Common Warning** outputs will close and the red LED above **STOP** button will blink. Warning symbol will blink in the upper-right corner of the LCD and the proper warning symbol will be displayed in the history with running hours stamp. Active warning can't be confirmed.



Figure 3.4
active warning – Low Battery

3.2.2 Inactive warning

When a warning becomes inactive, [O04 Alarm](#) and [O15 Common Warning](#) output will open, the red LED above **STOP** button will stop blinking, and the warning symbol  on main screen will go out.



Figure 3.5
inactive warning – Low Battery

3.3 Shutdowns

3.3.1 Shutdown procedure

The **InteliNano^{NT}** controller opens outputs [O05 GCB Close/Open](#), [O01 Starter](#), [O08 Prestart](#) and [O02 Fuel Solenoid](#) and closes [O03 Stop Solenoid](#) to stop the engine immediately. [O04 Alarm](#) and [O16 Common Shutdown](#) outputs are closed. Active or not confirmed shutdowns are blocking next start of gen-set.

3.3.2 Active unconfirmed shutdown

When a shutdown occurs, the **Shutdown procedure** will start, the red LED above **STOP** button blinks, the shutdown symbol  will blink in the upper right corner of LCD, and the proper shutdown symbol is displayed in history with running hours stamp. The record in history is inversed, see **Figure 3.6**. For shutdown alarm confirmation press **STOP** button.



Figure 3.6
active unconfirmed shutdown – Emergency Stop

3.3.3 Active confirmed shutdown

When an active shutdown is confirmed the red LED above the **STOP** button stops blinking. The record in history stays inversed with confirmation symbol at the end. [O04 Alarm](#) and [O16 Common Shutdown](#) outputs are open.



Figure 3.7
active confirmed shutdown – Emergency Stop

3.3.4 Inactive unconfirmed shutdown

[O04 Alarm](#) and [O16 Common Shutdown](#) outputs are closed, red LED above **STOP** button blinks. Shutdown symbol  is displayed in upper-right corner of the LCD, and proper warning symbol is displayed in history with running hours stamp. See **Figure 3.8**. For shutdown alarm confirmation press **STOP** button.



Figure 3.8
inactive unconfirmed shutdown – Emergency Stop

3.3.5 Inactive confirmed shutdown

[004 Alarm](#) and [016 Common Shutdown](#) outputs are opened. It is possible to start engine when all shutdowns are inactive and confirmed.



Figure 3.9
inactive confirmed shutdown – Emergency Stop

3.4 ECU Messages



Figure 3.10
ECU message

	<p>ECU Message</p> <p>Diagnostic messages are read and displayed in the history behind the ECU Warning symbol. For Standard J1939 SPN (Suspect Parameter Number) and FMI (Failure Mode Identifier) are shown.</p> <p>Detail SPN/FMI code specification see in:</p> <ul style="list-style-type: none"> • SAE Truck and Bus Control and Communications Network Standards Manual, SAE HS-1939 Publication • Or refer to corresponding engine manufacturer's ECU error codes list. <p>Complete list of text diagnostic messages for each ECU can be found in ComAp Electronic Engines Support manual.</p>
--	--

4 Start and Stop engine

4.1 MANUAL mode

Green LED above **AUTO** button is off (controller is in MANUAL mode). When there is no any active shut down alarm you can start the engine by pressing **START** button. Green LED above button will blink. LED is blinking during starting, cooling or stopping procedure. When the engine is properly started, the green LED will stop blink and start lights continuously. The generator is ready to load. When you press **START** button again the GCB will close – only when the GCB is configured.

Press **STOP** button to stop the engine. First press will open the GCB and next press start cooling and stopping procedure. When you press this button again the controller will stop the engine immediately. For fast engine stop press and hold **STOP** button till engine stops.

4.2 AUTO mode

Green LED above **AUTO** button is on (controller is in AUTO mode). You can't start the engine or connect the load by pressing **START** button. The controller will start automatically when all conditions for start and connecting load will be reached. The engine in AUTO mode can't be stopped by pressing **STOP** button.

Engine can be started or stopped via binary inputs [I02 Remote Start/Stop](#) or [I03 Remote Start And Load](#). For more details see IntelliNano^{NT} MRS 3 Reference Guide.