

EA75A220

Generator Automatic Voltage Regulator Operation Manual



Self Excited Automatic Voltage Regulator
75 Amp AVR for Carbon Brush Type Generators
EA75A220HL (Half Wave) / EA75A220FL (Full Wave)

*Parallel version is available for option



KUTAI ELECTRONICS INDUSTRY CO., LTD.

TEL : +886-7-8121771

FAX : +886-7-8121775

Website : www.kutai.com.tw

Headquarters : No.3, Ln. 201, Qianfu St., Qianzhen Dist., Kaohsiung City 80664, Taiwan



SECTION 1 : SPECIFICATION

Sensing & power Input

Voltage 170 – 265 Vac, 1 phase 2 wire
 Frequency 50 / 60 Hz

Under Frequency Protection (Factory Presets)

50 Hz system presets knee point at 45 Hz
 60 Hz system presets knee point at 55 Hz

Excitation Output (at 220 Vac input)

Voltage EA75A220HL(Half-wave) Max.90 Vdc
 EA75A220FL(Full-wave) Max.180 Vdc
 Power input 220 Vac
 Current Continuous 75A
 Intermittent 100A for 10 secs.

Environment

Operating Temperature -40 to +60 °C
 Storage Temperature -40 to +85 °C
 Relative Humidity Max. 95%
 Vibration 3 Gs @ 100 – 2K Hz

Resistance EA75A220HL Min. 0.9 ohms
 EA75A220FL Min. 1.6 ohms

Cooling condition

Forced with 120.0 (L) x 120.0 (W) x 38.0 (H) mm fan

External Voltage Adjustment

+/- 6%

Dimensions

420.0 (L) x 191.0 (W) x 180.0 (H) mm

Voltage Regulation

Less than +/- 1% (with 4% engine governing)

Weight

EA75A220HL 6.6 kgs +/- 2%
 EA75A220FL 8.0 kgs +/- 2%

Build Up Voltage

5 Vac 25 Hz residual volts at power input terminal

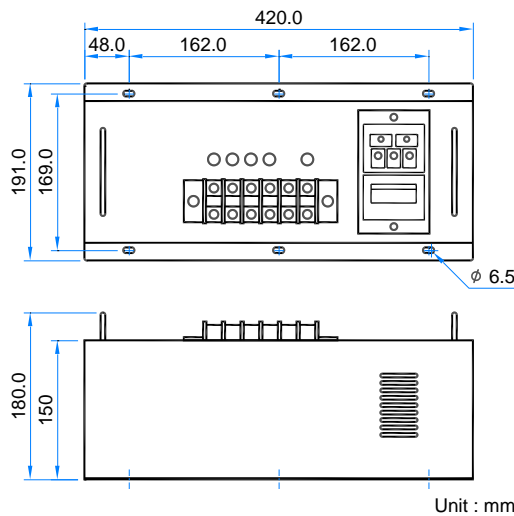

Outline Drawing
 Figure 1

SECTION 2 : ADJUSTMENT

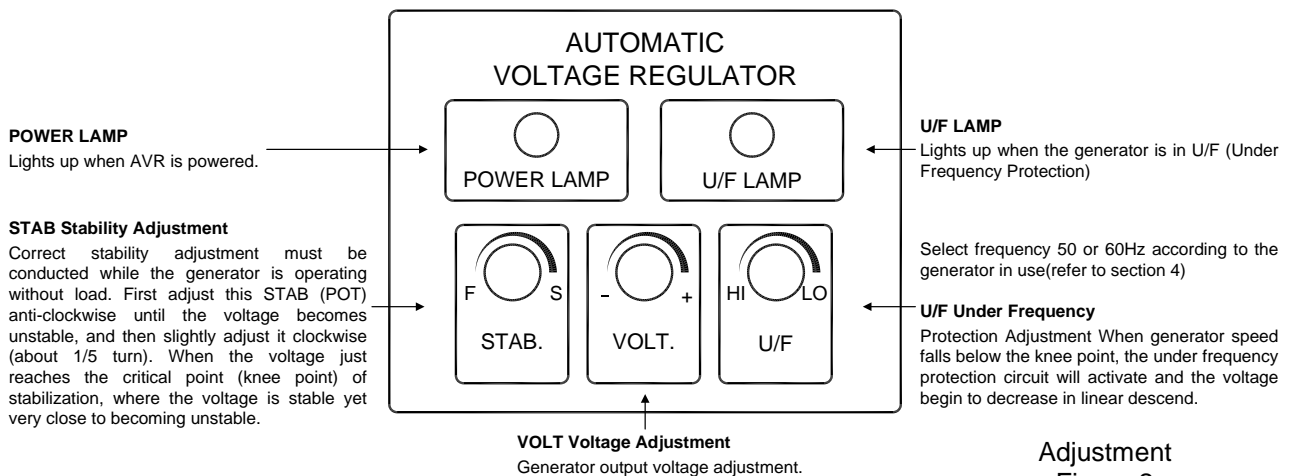

Adjustment
 Figure 2

SECTION 3 : WIRING CONNECTION

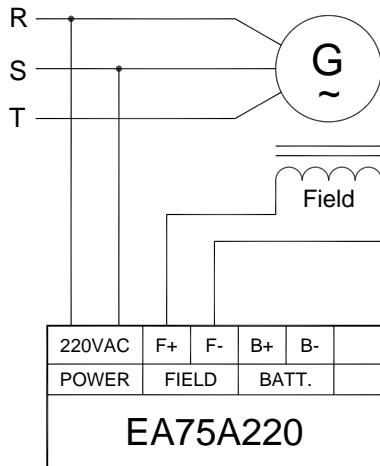

Figure 3

SECTION 4 : FREQUENCY SELECTION AND KNEE POINT ADJUSTMENT

4.1 Frequency Selection

Detach the controller from enclosure (refer to Figure 4) and select the system frequency on the back of the controller (refer to Figure 5).

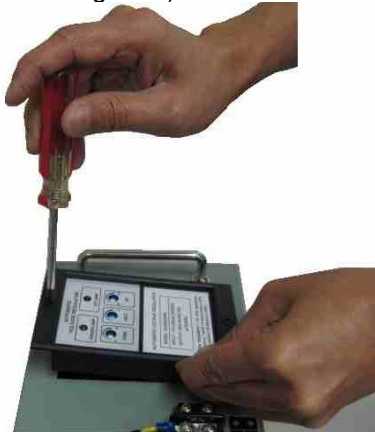

Figure 4

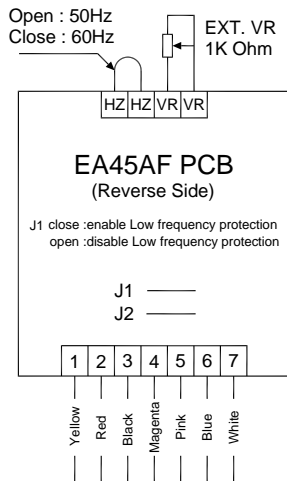

Figure 5

4.2 Knee Point Adjustment

- 4.2.1 Turn the U/F POT fully clockwise.
- 4.2.2 Adjust VOLT POT to nominal level and speed down the engine to knee point.
- 4.2.3 Turn the U/F POT counter-clockwise until the voltage starts to decrease (U/F lamp illuminates), re-adjust engine speed to rated speed.

SECTION 5 : FIELD FLASHING

When the regulator is installed correctly but the generator is failed to generate power. Besides carbon brushes were worn out, here are two possible causes below.

5.1 The polarity of field is reversed

Solution : Exchange the connection of F+ and F-.

5.2 The residual voltage is less than 5 Vac, Solution 1 :

5.2.1 Shut down generator, disconnect the wiring between AVR and generator then flash the field. Flashing duration = 3 seconds. (See wiring in Figure 6)

Resistor 3 – 5 ohms for full wave AVR

Resistor 5 – 10 ohms for half wave AVR

Warning!! Over field flashing may damage the field winding of generator.

5.2.2 Restart generator and measure the residual voltage by AC Voltmeter, if it is still less than 5 Vac, repeat the previous process, after several times, the residual voltage still cannot be built, Kutai EB500 is strongly recommended, see Figure 6.

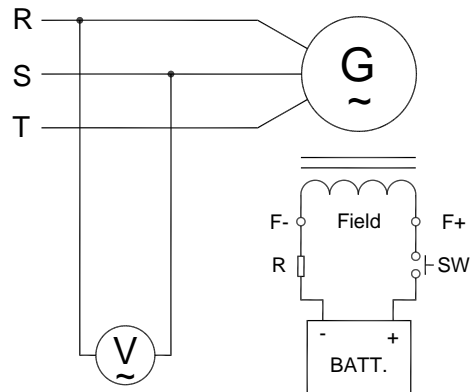

Figure 6 Manual Field Flash

Solution 2 : Install Kutai automatic flash module EB500

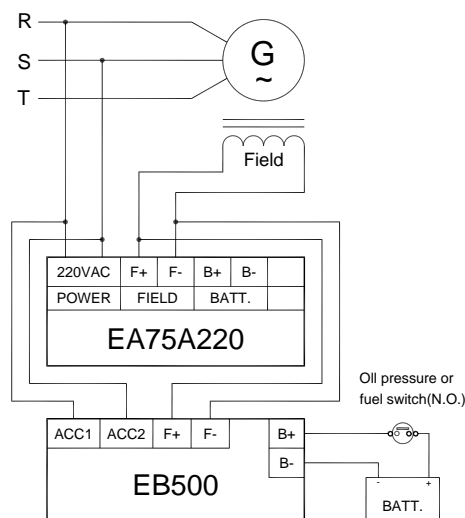

Figure 7

WARNING

This Automatic Voltage Regulator is not equipped with loss-Sensing Protection function / Over Excitation Protection. An additional Over-Voltage Protection device for load may be required to avoid possible damage to the equipment or severe personal injury or death.

ATTENTION

1. AVR installation should only be performed by a qualified technician.
2. Install AVR inside the generator control panel to avoid high temperature, moisture, and location where AVR cannot be easily reached.
3. AVR heat sink may reach a high temperature (above 60 °C) when AVR is powered, do not touch or ground AVR heat sink.
4. Make sure you have read and understand the contents of the instruction manual prior to installation. Incorrect wiring connection may result in irreversible damage to the product and other equipments.

SECTION 6 : TROUBLE SHOOTING

SYMPTOM	POSSIBLE CAUSES	SOLUTIONS
Voltage does not build up	Residual voltage below 5 Vac	Field flash is required
	Incorrect wiring	Check wiring diagram for proper connection
	Engine under speed	Increase engine speed to above 25 Hz
	Carbon brushes were worn out	Replace with new carbon brushes
Low output voltage	Voltage set point is not properly adjusted	Adjust VOLT POT clockwise to reach desired voltage
	External voltage adjusted too low	Turn the external VR to reach desired voltage
	Under Frequency Protection is activated	Refer to Section 4 Frequency selection and knee point adjustment
Over output voltage	Voltage set point is not properly adjusted	Adjust VOLT POT anti-clockwise to reach rated voltage
Output voltage unstable (Hunting)	Stability range is not set properly	Refer to Section 2 Adjustment
	Field voltage or field resistance is too low	Connect appropriate resistors in series to increase total impedance

※ Appearance and specifications of products are subject to change for improvement without prior notice.