

# ADVR-054

## ***Universal Hybrid Analog-Digital Voltage Regulator Operation Manual***



Self Excited 5 Amp Analog / Digital Voltage Regulator  
For shunt and auxiliary windings generators  
With over-excitation and lost of sensing protection  
Use with Kutai EP200 Paralleling Module for parallel operation



**KUTAI ELECTRONICS INDUSTRY CO., LTD.**

TEL : +886-7-8121771

FAX : +886-7-8121775

Website : [www.kutai.com.tw](http://www.kutai.com.tw)

Headquarters : No.3, Ln. 201, Qianfu St., Qianzhen Dist., Kaohsiung City 80664, Taiwan

ISO 9001  
**ETC**

## WARNING

1. Some generators even when working at high voltage are factory set to sense at lower voltages. Remember to set the DIP SW 2 to the sensing voltage not the working voltage of the generator even do sometimes it can be the same. If you have a 480/277V generator but you have the sensing wires C and A connected to 240 Volts move DIP SW 2 to ON

Another example are rental units with multi-voltage output with a switches for Y, YY, Delta & ZZ output, but sensing is always at 240V from T7 and T9 even though the generator is running sometimes at 480/277V.

2. All voltage readings are to be taken with an average-reading voltmeter Meggers and high-potential test equipment must not be used. Use of such equipment could damage the AVR.
3. Improper setting of under-frequency protection could cause the output voltage of the unit to drop or become unstable under with changes in load. Avoid making any changes to the U/F setting unless necessary.

## SECTION 1 : SPECIFICATION

### Sensing Input (A, C) Average Reading

Voltage 170 – 260 Vac @ 220 Vac, 1 phase 2 wires  
340 – 520 Vac @ 440 Vac, 1 phase 2 wires  
220/440 Vac, DIP switch setting  
Frequency 50/60 Hz, DIP switch setting

### Power Input (B, C)

Voltage 100 – 300 Vac, 1 phase 2 wires  
Frequency 40 – 60 Hz

### Excitation Output (F+, F-)

220V 1 phase Continuous 63 Vdc 5A  
Max. 90 Vdc 7A for 10 secs.  
Resistance Min. 15 ohms, Max. 100 ohms  
Fuse Spec. Slow blow 5 x 20mm S505-5A

### External Voltage Adjustment (EXT.VR)

Max. +/- 3.5% @ 1K ohm 1 watt potentiometer

### Voltage Regulation

Less than +/- 0.5% ( with 4% engine governing )

### Build Up Voltage

5 Vac 25 Hz residual volts at power input terminal

### Soft Start Ramp Time

3 seconds +/- 10%

### Typical System Response

Less than 20 milliseconds

### EMI Suppression

Internal electromagnetic interference filtering

### Static Power Dissipation

Max.8 watts

### Under Frequency Protection (Factory Presets)

50 Hz system presets knee point at 45 Hz  
60 Hz system presets knee point at 55 Hz

### Over Excitation Voltage Protection

Set point 78 Vdc +/- 6% @ power input 220 Vac  
Time delay 5 secs. This function can be turned off.

### Voltage Thermal Drift

Less than 3% at temperature range -40 to +70 °C

### Under-Frequency Knee Point Thermal Drift

Less than +/- 0.1 Hz at -40 to +70 °C

### Environment

Operating Temperature -40 to +60 °C  
Storage Temperature -40 to +85 °C  
Relative Humidity Max. 95%  
Vibration 5 Gs @ 60 Hz

### Dimensions

121.0 (L) x 81.0 (W) x 44.5 (H) mm  
4.76 (L) x 3.19 (W) x 1.75 (H) inch

### Weight

270 g +/- 2%  
0.6 lb +/- 2%

## SECTION 2 : APPEARANCE / DIMENSIONS / INSTALLATION DRAWING

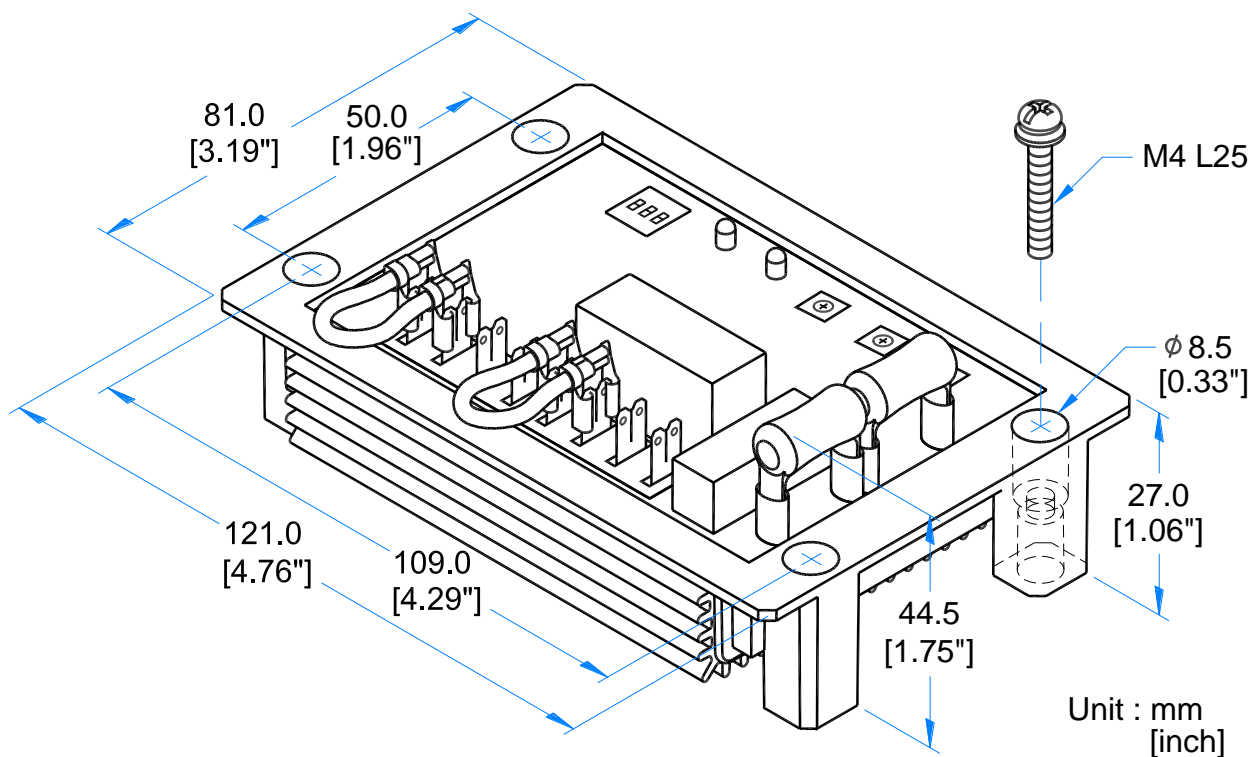

Figure 1 Outline Drawing

### ATTENTION

1. Only qualified technicians should install and operate the AVR.
2. The voltage regulator may be installed at any suitable location on the generator set (dimensions are shown in Figure 1). It is recommended that unit is mounted vertically with the green resistors on the regulator upwards to achieve the best cooling effect.
3. All AC voltage sensing readings are average value only.

### SECTION 3 : DIP SWITCH SETTINGS, LED INDICATORS AND ADJUSTMENTS

**Over Excitation (O/E) LED**

When the excitation voltage is greater than 35% of input power voltage, the LED will lit after 5 sec. If the DIP switch SW3 set at OFF then it will also shut off excitation output at the same time.

**U/F LED**

Under Frequency Protection status.

**DIP Switches**

System Frequency **SW1 ON:50 Hz, OFF:60 Hz**  
 Sensing Input **SW2 ON:220V, OFF:440V**  
 O/E Protection **SW3 ON:Disable, OFF:Enable**



**VOLT Voltage Adjustment**

The adjustment range is set by SW2.



**STAB Stability Setting**

With No Load, slowly turn the STAB counterclockwise until voltage becomes unstable then turn clockwise about 1/5 turn.



**U/F Under Frequency Protection**

50 Hz system preset at 45 Hz, 60 Hz system preset at 55 Hz, To change the setting, see the Adjustment Step 3.

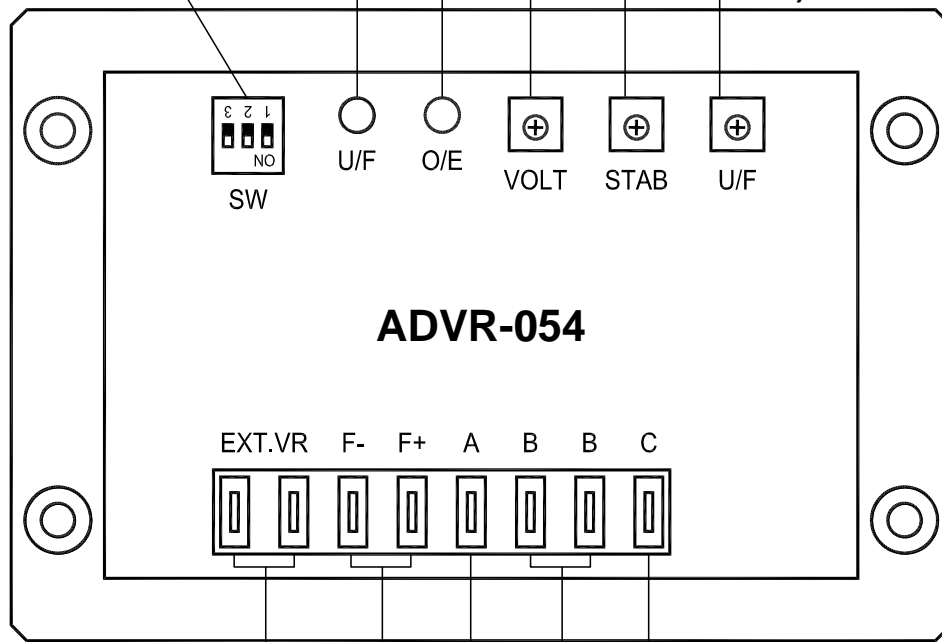

**EXT.VR Ext Potentiometer,**

1K ohm 1W. Keep shorted when not in use.

**F+ , F- :** Connect to generator excitation field.

**C :** Sensing Input and Power Input terminals

**B :** Power Input terminal  
 B to C: always less than 300 Vac

**A :** Sensing Input terminal  
 A to C: 170 – 520 Vac

**ADJUSTMENTS AFTER GENERATOR IS STARTED :**

1. First, turn VOLT and STAB trimpots fully counterclockwise before starting the generator. Set the engine governor to 50 or 60 Hz. Start the generator and wait till it reaches rated speed. Now slowly turn VOLT trimpot clockwise to increase the working voltage. (If you use an external potentiometer, set it to the center position). Keep EXT. VR shorted when not in use.
2. Next, slowly adjusting the STAB trimpot etting (clockwise), this change the response time of the AVR to changing loads. If the setting is too high the voltage is unstable but if set too low the response is sluggish. We recommend using an analog DC voltage meter on F, F+ and adjust STAB for the lowest amount of voltage fluctuation (needle movement).
3. Last, Under Frequency (U/F) adjustment. (The U/F is Factory preset and needs no adjustments) put in rare applications. Use the U/F LED as a guide. When this LED is ON the circuit is operational turning off the regulators output. To recalibrate, adjust the generator speed to the new U/F kneel point, usually 5 Hz under rated speed (Hz) then set the U/F trim-pot to the point at which the U/F LED just changes from off to on rated speed (Hz) then set the U/F trimpot to the point at which the U/F LED just changes from off to on. Adjustment range for 50Hz system is 40 to 51 Hz. For 60 Hz system the range is 50 to 61 Hz.

## SECTION 4 : CONNECTION DIAGRAMS

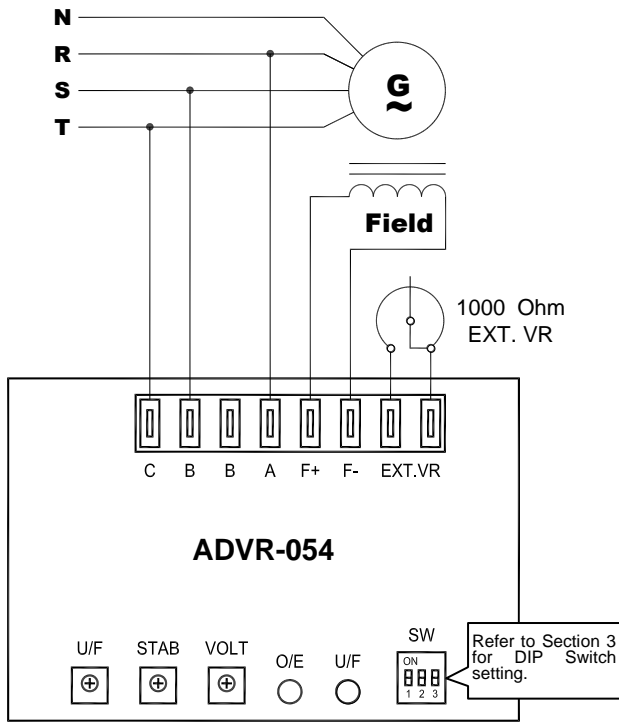

Figure 3 170 – 260V sensing connection (Option 1)

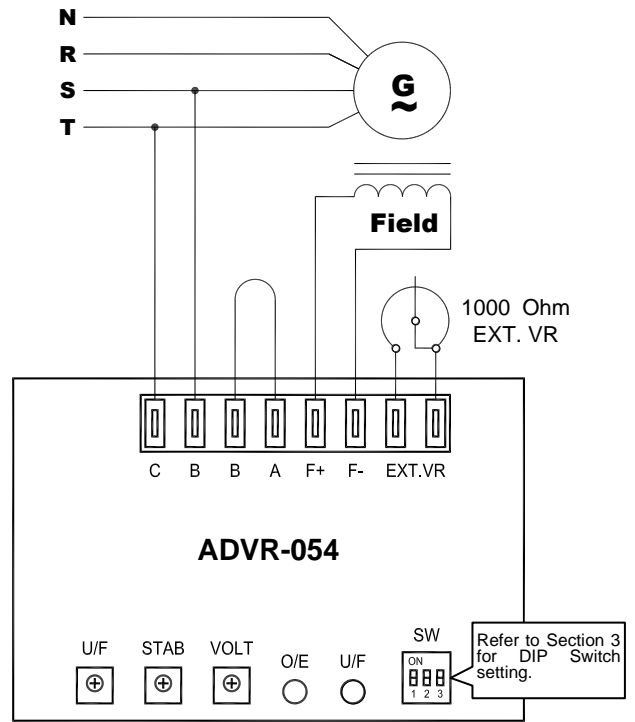

Figure 4 170 – 260V sensing connection (Option 2)

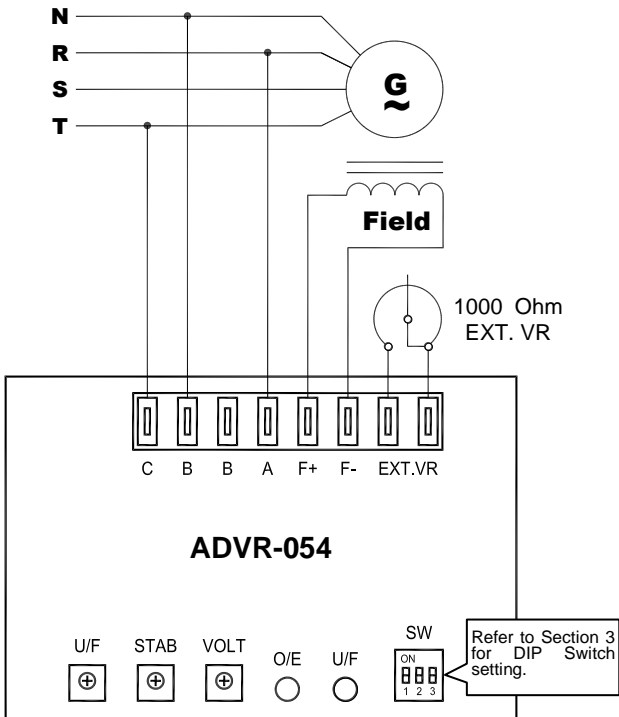

Figure 5 340 – 520V sensing connection

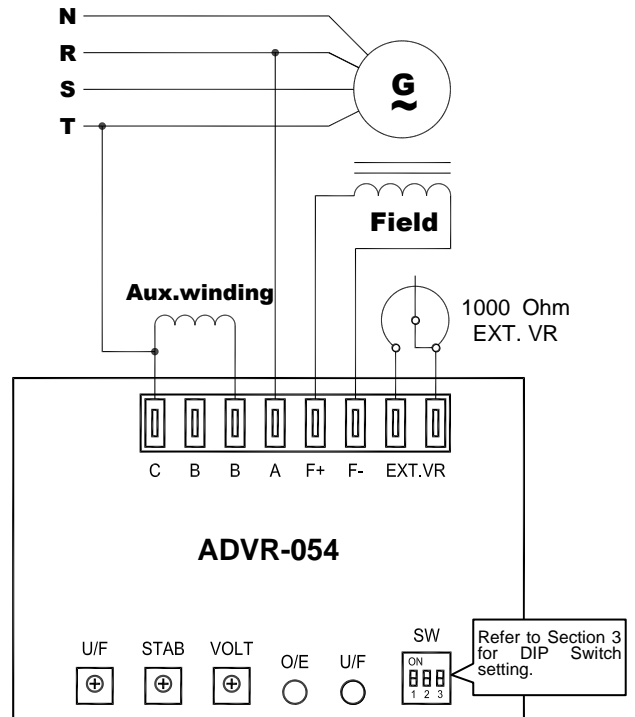

Figure 6 Auxiliary Winding connection

- ※ Package include 4 pcs of M4 L25 Round head bolts and 2 pcs of terminal jumpers.
- ※ Use only replacement fuses specified in this user manual.
- ※ Appearance and specifications of products are subject to change for improvement without prior notice.