



User manual

GC250

File name: EAAM057703EN.docx
Rev. 03 Date: 04/08/2020
Document ID: EAAM0577
Product: GC250

INDICE

1	Safety information	3
2	Maintenance and cleaning	3
3	Information concerning disposal	3
4	General information	3
5	Definitions	3
6	Main functions	5
6.1	Front panel	5
6.2	Buttons	6
6.3	Indicators	7
6.4	Multifunction display	8
6.4.1	Display lighting	8
6.4.2	Contrast adjustment	8
6.4.3	Navigation between display modes	8
6.4.4	Structure of display area	9
6.4.5	Top status bar	9
6.5	Display modes	10
6.5.1	Program (P.XX)	10
6.5.2	Status information (S.XX)	13
6.5.3	Electrical measurements (M.XX)	16
6.5.4	Engine measurements (E.XX)	17
6.5.5	HISTORY LOGS (H.XX)	19
7	Operating principles	20
7.1	Plant types	20
7.1.1	SSB	20
7.1.2	SPM	20
7.2	Operating modes	22
7.2.1	Off/Reset	22
7.2.2	Automatic	22
7.2.3	Manual	23
7.2.4	TEST	24
8	Date/time setting	25
9	Fuel pump (if present)	25
9.1	Operating selection	25
10	Energy saving	26

PREMESSA

The manual must be kept with care and must always be available for quick reference. The manual must be carefully read and understood in each of its paragraphs by the people who must use the controller and who will carry out normal and periodic maintenance.

If the manual is lost or damaged, request a copy from the installer or the manufacturer, providing the model, device code, serial number and year of construction.

1 Safety information

Many accidents are caused by insufficient knowledge and failure to apply the safety rules during standard and/or maintenance operations.

To avoid accidents, before performing any operation and/or maintenance, read, understand and follow the precautions and warnings contained in this manual.

The following indications have been used to identify the safety messages included in this manual:



WARNING! This indication is used in safety messages for dangers which, if not avoided, can cause malfunctions or damage to things or people.



INFORMATION! This term indicates that the message provides information useful for carrying out the operation in progress or for clarifying or specifying procedures.

2 Maintenance and cleaning

Maintenance of this device must be carried out by qualified personnel, in compliance with current regulations, in order to avoid damage to people or things.

The front panel can be cleaned only with a soft cloth, do not use abrasive products, liquid detergents or solvents.

3 Information concerning disposal



INFORMATION! Disposal of old electrical and electronic equipment (valid for European countries that have adopted separate collection systems).



Products bearing the symbol of a crossed-out wheeled bin cannot be disposed of with normal household waste. Old electrical and electronic products must be recycled at a special facility capable of treating these products and disposing of their components. To find out where and how to deliver these products to the place closest to you, contact the appropriate municipal office. Proper recycling and disposal helps to preserve nature and prevent harmful effects on health and the environment.

4 General information

This manual describes the GC250 controller.

5 Definitions

BLOCK: it is used to indicate an anomaly that makes the generator impossible to operate and causes the automatic and immediate shutdown of the engine with an emergency procedure.

DEACTIVATION: it is used to indicate an anomaly that makes the generator impossible to operate and causes the engine to automatically shut down with the standard procedure (with the cooling phase).

WARNING: it is used to indicate an anomaly that requires an action by the operator but does not stop the engine.

MAINS: public electricity.

GENERATOR: a synchronous generator made up by a combustion engine (diesel, gas...) and an alternator.

LOADS: utilities.

MCB: circuit breaker that connects the mains to the loads.

GCB: circuit breaker that connects the generator to the loads.

CANBUS: communication interface for the control and diagnostics of engines equipped with SAE J1939 or MTU MDEC protocol.

ISLAND: application in which the generator feeds the loads without being in parallel with the mains.

SPM (Single Prime Mover): island application where the mains is never available, and the genset is always running.

SSB (Single Stand By): island application where the genset runs only in case of mains failure.

6 Main functions

6.1 Front panel

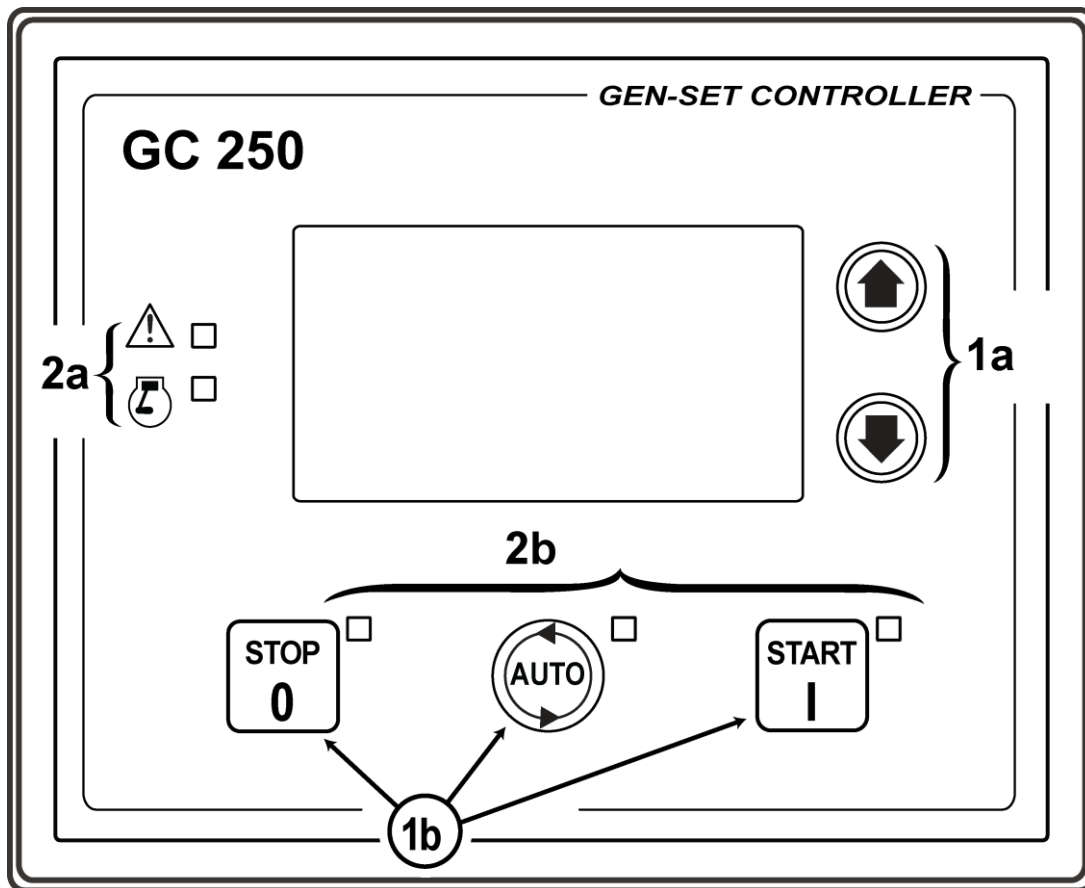

Fig. 1 – Front panel





Legend

- 1) Buttons
- 2) Indicators

Commands are available by five buttons (1a, 1b).





Five lamps are available for indications (2a, 2b).

6.2 Buttons

Push-button		Function
	UP	It shows the next page or the next menu; if kept pressed for at least one second, it allows going to the upper level menu.
	DOWN	It shows the previous page or the previous menu; if kept pressed for at least one second, it allows entering to the lower level menu.
	STOP / OFF-RESET	<p>In AUTO, MAN, TEST or REMOTE START operating modes it is used to stop the engine, and forces the OFF/RESET mode.</p> <p>In AUTO, TEST or REMOTE START, the button can be configured in two ways (bit 0 of P.0495):</p> <p>It stops the engine with the activation of a block.</p> <p>No function. The pushing of a button is irrelevant.</p> <p>Pressed in OFF/RESET mode it switches on all the lamps allowing to check their efficiency (LAMP TEST).</p> <p>In OFF/RESET mode, pressed for at least one second together with the AUTO button, allows to access the programming menu.</p> <p>If pressed together with the START button while the controller is powered, it allows access to the special functions.</p>
	AUTO	By pressing the button for around half a second, the controller switches in AUTO operating mode, providing for the automatic management of the generator, which will be started when the conditions require it.
	START / MANUALE	<p>By pressing the button for around half a second, the controller switches in MAN operating mode, providing for the manual management of the generator.</p> <p>If the “Protected Start” function (bit 2 of P.495) is disabled, the engine is immediately started (according to the two following ways); if enabled, by pressing one time, you select only the MAN operation mode and it is necessary to press it another time to start the engine.</p> <p>The button can also be configured to start the engine in two different ways (bit 1 of P.0495):</p> <ul style="list-style-type: none"> Fully manual (the starter motor is engaged all the time the button is pressed, until the engine running condition is detected). Fully automatic: simply press and release the START button to activate an automatic start sequence. If the engine does not start, no alarms will be reported. The START button must be pressed and released again to perform a new start attempt. <p>If pressed together with the STOP button while the controller is powered, it allows access to the special functions.</p>

6.3 Indicators

Led off	LED steady ON	LED flashing
□	■	◻

	Signalling		Function
		■	Indicates that the operation mode is OFF/RESET .
		◻	Indicates that you are accessing the PROGRAM menu
		□	The controller is in another operating mode.
	AUTO	■	Indicates that the operation mode is AUTO .
		◻	Flashing at 50% indicates that the operating mode is TEST .
		◻	Flashing at 90% indicates that the operating mode is REMOTE START .
		□	The controller is in another operating mode.
	MANUAL	■	Indicates that the operation mode is MAN .
		◻	Indicates that the operation mode is MAN and that the protected start mode is active.
		□	The controller is in another operating mode.
	ALARM	■	Indicates the presence of at least one block or one deactivation.
		◻	Indicates the presence of at least one warning.
		□	No anomalies.
	ENGINE RUNNING	■	Indicates engine running.
		□	Indicates engine stopped.

6.4 Multifunction display

6.4.1 Display lighting

The backlighting lamp is managed by the controller which switches it off if no button is pressed within a configurable time (P.0492). To turn it back on, just press any button. It is possible to disable the automatic switch off by setting parameter P.0492 to 0.

During the engine start-up phase, the lamp is automatically turned off to reduce the consumption of the controller, in order to make the controller more autonomous in case of critical conditions of the starter battery. By using parameter P.0493, it is possible to force the lamp always switched on when the engine is running.

6.4.2 Contrast adjustment





For a correct view of the display, depending on the ambient temperature conditions, the contrast adjustment may be necessary.

Press the **AUTO+DOWN** buttons in sequence to decrease the contrast (lighten), press the **AUTO+UP** buttons to increase it (darken).

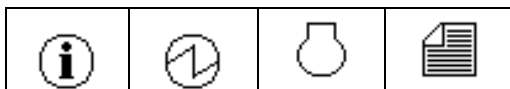
6.4.3 Navigation between display modes

The display has different viewing modes consisting of several pages.



Mode	Icon	Description	Page identifier
PROGRAM		Programming	P.XX
STATUS		Status information	S.XX
MEASURES		Electrical measurements	M.XX
ENGINE		Engine measurements	E.XX
HISTORY		History logs	H.XX

Generally, navigation between the modes takes place by keeping the **UP** and **DOWN** buttons pressed for at least one second.

Pressing the **UP** button for at least one second opens the navigation menu between the modes (a window with icons identifying the available modes). With **UP** and **DOWN** buttons is then possible to scroll the available modes.

Finally, keeping the **DOWN** button pressed for at least one second, it selects and shows the desired mode.

The **UP** and **DOWN** buttons are also used to scroll the pages within the selected display mode.

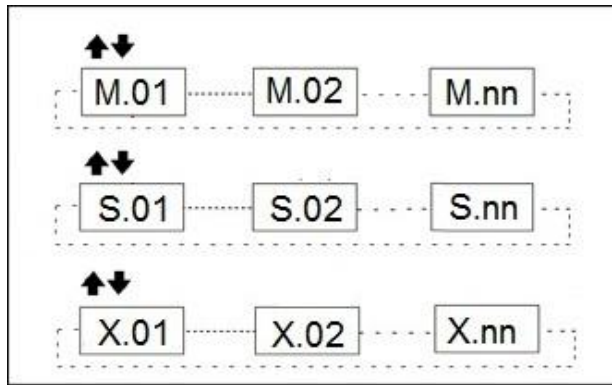

6.4.4 Structure of display area

LEGEND:

- 1 – Top status bar.
- 2 – Data area.

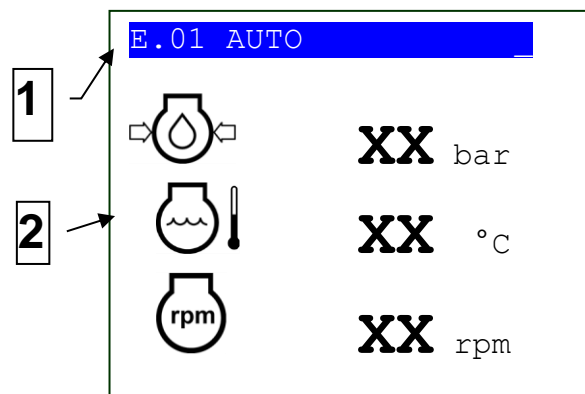

Fig. 3 – Visualization area

6.4.5 Top status bar

The top status bar contains navigation, time and/or some status information.

LEGEND:

- 1a – Mode identifier.
- 1b – Page identifier.
- 2 – Operating mode

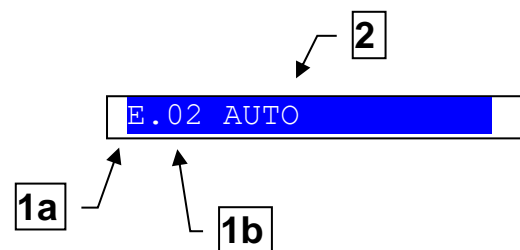



Fig. 4 – Top status bar

The current display mode is indicated by the appropriate field on the top status bar (1a). The mode identifier (1a), together with the page identifier (1b) allows you to identify and refer unambiguously to a page.

The title shows the operating mode of the controller (2), which can be **OFF**, **MAN**, **AUTO**, **TEST**, and **REMOTE START**. It is useful for the operator, as it is displayed even if he is accessing other pages or display modes.

6.5 Display modes

6.5.1 Program (P.XX)

 **WARNING!** The incorrect programming of one or more parameters can cause malfunctions or damage to things and/or people. Parameter changes must only be carried out by qualified personnel. The parameters can be password protected (see par. Access codes).

 **INFORMATION!** In programming, the **STOP**, **AUTO** and **START** buttons have different functions and cannot be used to change the controller's operating mode and to control the engine.

To exit the programming menus and return to the main screen, press the **STOP** button repeatedly.

Access to PROGRAM function is available only in **OFF/RESET** mode by holding the **STOP** and **AUTO** buttons simultaneously for at least 1 second.

Use the **UP** and **DOWN** buttons to select a menu, **AUTO** to enter it.

P.01	OFF	
Main menu		1/06
1	System	
2	Sequence	
3	Protection	
4	Aux. functions	
5	Communication	
7	Can bus	
8	Plant	

6.5.1.1 Access codes

Access to parameter programming can be limited by means of 3 different password levels listed in order of priority:

- Manufacturer.
- Installer.
- User.

In case a password is lost, it is possible to reconfigure it by "logging in" with a higher access level. In case of loss of the MANUFACTURER password, please contact the support team.

A password is not assigned if it is equal to 0.

Please do the "Log in" procedure on page 1.1.1 **Authentication**, typing your password into parameter **000** ("**Access code**"). To do this, please navigate the various menus and submenus following the path: **PROGRAM** → **1. SYSTEM** → **1.1 Security** → **1.1.1 Authentication**. If, when entering the PROGRAM function, the display does not show the main menu (like in the previous picture), press the **STOP** button until the main menu becomes visible.

After authenticating with an access code, it is possible to modify or delete the password for the authenticated level or lower levels (menu **1.1.2 password**).

 **WARNING!** Critical parameters must not be changed by the user.

The "log in" operation is valid for a period of about 10 minutes from the end of programming. After this period, the access code must be entered again to access programming.

6.5.1.2 Parameters setting

This mode allows the display and modification of the programming parameters.

Use the **UP** and **DOWN** buttons to select the parameter or the submenu. Pressing **AUTO**, when there are no submenus, the parameters of that menu item are shown.

The value of the parameter is displayed enclosed in square brackets, for example “[0400]”

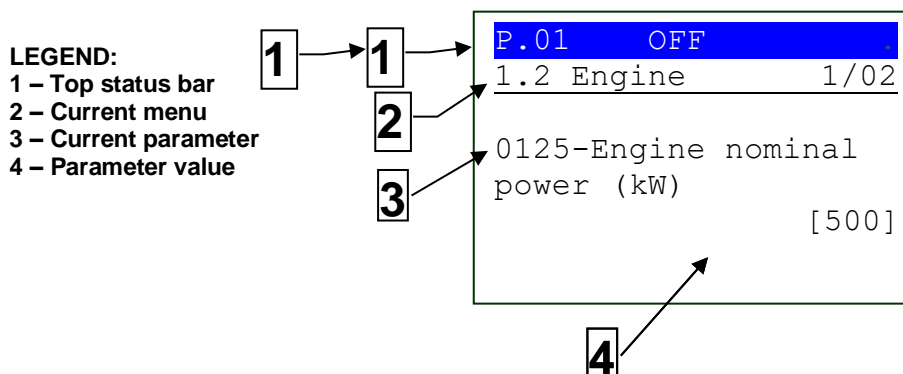

Fig. 1 - Visualization area

A 4 digits numeric code is associated to each parameter (for example P.0125), allowing to identify the parameter despite the selected language.

The current value of the parameter is shown below its description, between square brackets. If, instead, it is enclosed between “<” and “>” symbols (“<400>” for example), it means that you have no rights to modify the value: you may need to change the operating mode to OFF/RESET or to “log in” with the proper access code.

The first row below the top status bar allows to identify the selected menu by its number and its description. The same row shows (on the right) two numbers (1/2 in the example): the first is the index of the currently selected menu item, the second is the total number of items in the menu.

To modify the parameter value, press the **AUTO** button: the square brackets [...] become flashing. Use the **UP** and **DOWN** buttons to change the value and press **AUTO** to confirm or **STOP** to abort the change.

6.5.1.3 Setting string parameters

Some parameters are shown as alphanumeric or hexadecimal strings.

In this case, when the **AUTO** button is pressed, in addition to flashing the two square brackets [...] that enclose the variable, a cursor is activated under the first character of the string.

With the **STOP** and **START** buttons it is possible to move the cursor under the character to be modified. Subsequently, using **UP** and **DOWN** buttons it is possible to modify the selected character. The operation is to be repeated for all the characters to be changed.

Use the **AUTO** (confirm) or **STOP** (abort) buttons to end the procedure.

6.5.1.4 Parameters for protections and alarms

The protections and alarms are generally configurable by means of specific parameters. Normally, the trip time associated with the protection can also be configured.

 **INFORMATION!** By setting the tripping time to 0, the protection is disabled.













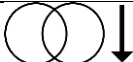
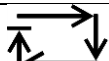
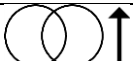

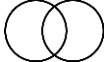





6.5.1.5 Leaving the PROGRAM function

To exit the PROGRAM function and return to the main screen, press the STOP button repeatedly.

6.5.2 Status information (S.XX)

This mode provides information on the system status. It is possible to scroll through the different pages using the **UP** and **DOWN** buttons.

The **S.01 (STATUS)** page displays system status information.

Operating modes		Status of the mains	
	OFF/RESET mode.		No voltages (flashing)
	MANUAL mode.		Low voltage (flashing)
	AUTOMATIC mode.		High voltage (flashing)
	REMOTE START mode.		Voltage present and in tolerance.
	TEST mode	Status of the generator	
Engine command sequence status			No voltages (flashing)
	Stopped.	Low voltage (flashing)	Low voltage (flashing)
	Preheating plugs (DIESEL).	High voltage (flashing)	High voltage (flashing)
	Cranking.	Voltage present and in tolerance.	Voltage present and in tolerance.
	Delay between two crank attempts.	Circuit breakers status	
			MCB circuit breaker closed.
	Delay before supply.		GCB circuit breaker closed.
			Both circuit breakers open.
	Running.	Engine start inhibitions	
	Cooling down.		Start allowed
	Stopping.		Start inhibited



For many of this information, a time is also shown; for example, during the engine cooling cycle the time remaining at the end of this cycle is shown.

The **S.02 (ANOMALIES)** page is automatically displayed in case of a new anomaly. For each anomaly, the following is shown:

- A letter identifying the type:
 - "A": block.
 - "D": deactivation.
 - "W": warning.
- A three-digit numeric code that uniquely identifies the anomaly. This code flashes if the anomaly has not yet been recognized with any of the buttons.

The page **S.03 (USB / CANBUS COMMUNICATION)** displays the status of the communication over the USB port and over the CANBUS interface of the controller. In case of communication problems, check the information on this page.

USB: The status of communication via USB is displayed via the symbols:

-  Communication in progress.
-  No communication in progress.

CANBUS: there are three possible indications:

- ERROR-ACTIVE: normal operation
- ERROR-PASSIVE: communication problems are present but communication is still functional.
- BUS-OFF: the controller has disconnected from the bus due to too many errors.

The instantaneous counters of the transmission/reception errors and the maximum values reached by them are also displayed. To reset the maximum values (and at the same time force the exit from the BUS-OFF state) it is necessary:

- Keep the **DOWN** button pressed: the counters will be highlighted.
- Press the **UP** and **DOWN** buttons for five seconds.

The page **S.04 (CONTROLLER)** displays the specific information of the controller: date/time, serial number (ID Code) and firmware revision.

The page **S.05 (DIGITAL INPUTS)**  shows the status of:



- Digital inputs of the controller.
- Analogue inputs of the controller, when used as digital (if they are not used as digital, dashes are shown).

By pressing the **DOWN** button, you can view the inputs in two different ways:

- **LOGIC STATUS:** the controller shows the logic level of the input (active or inactive) used in the management of the operating sequence.
- **PHYSICAL STATE:** the controller shows the electrical level (active or inactive, or high or low) actually present on the input; it can be opposite to the corresponding logical state. It is displayed in reverse.

The page **S.06 (DIGITAL OUTPUTS)**  shows the status of the digital outputs of the controller. By pressing the **DOWN** button, you can view the outputs in two different ways:

- **LOGIC STATUS:** the controller shows the logic level of the outputs (active or inactive) used in the management of the operating sequence.
- **PHYSICAL STATE:** the controller shows the electrical level (active or inactive, or high or low) actually present on the output; it can be opposite to the corresponding logical state. It is displayed in reverse.

The page **S.07 (ANALOGUE INPUTS)**   shows the status of the analogue inputs of the controller and of their reference terminal (T.12, T.13, T.14, T.15, T.09 and T.16). The controller shows the voltage on each terminal; for terminals T.13, T.14, T.15 it also shows the measurement in ohm.

6.5.3 Electrical measurements (M.XX)

This mode shows the measurements made by the controller on the power lines. It is possible to scroll through the different pages using the **UP** and **DOWN** buttons.

Page **M.01 (SYSTEM)** displays the layout of the system in a single-line format. The states of the circuit breakers, the mains, the generator and the electrical quantities reflect the configuration of the system.

Page **M.02 (MAINS 1)** (SSB application only) displays the main electrical quantities of the mains (L-L voltages, frequency and phases' sequence).

Page **M.03 (MAINS 2)** (SSB application only) displays the main electrical values of the mains (L-N voltages, neutral voltage and phases' sequence).

Page **M.04 (GENERATOR 1)** displays the main electrical quantities of the generator (L-N voltages, frequency and phases' sequence).

Page **M.05 (GENERATOR 2)** displays the main electrical quantities of the generator (L-N voltages, neutral voltage and phases' sequence).

Page **M.06 (CURRENTS)** displays the phase currents of the generator.

Page **M.07 (POWERS 1)** displays the active power (kW) and the power factor, total and on the individual phases.

Page **M.08 (POWERS 2)** displays the reactive (kvar) and apparent (kVA) powers, total and on the individual phases.

Page **M.09 (ENERGY)** displays both the total and partial energy meters, active (kWh) and reactive (kvarh).





INFORMATION! In single phase configuration some data are not displayed.

6.5.4 Engine measurements (E.XX)



This mode shows all the engine operating parameters. It is possible to scroll through the different pages using the **UP** and **DOWN** buttons.

Page **E.01 (ENGINE 1)** displays the main engine measurements:

-  : Oil pressure (bar).
-  : Coolant temperature (°C).
-  : Speed (rpm).



If the CANBUS connection is not available, it is possible to obtain the engine rotation speed from the generator frequency by entering the ratio between frequency and speed in parameter P.0127. On normal 6-poles alternators the rotation speed is 30 times the generated frequency.

Page **E.02 (ENGINE 2)** contains other measurement for the engine:

-  : Starter battery voltage (V) (measured by the controllers).
-  : Fuel level in the tank (%).
-  : Select model of CANBUS ECU.

If some of these measures are not available, they are displayed with dashes.

Page **E.03 (COUNTERS)** contains various counters (managed by the controller) that concern the engine:

-  : Crank counter (clearable).
-  : Running hours counter (clearable).
-  _T: Running hours counter (total, not clearable).



The first two counters can be reset (individually). To reset a counter, you need:

- Keep the **DOWN** button pressed: one of the counters will be highlighted.
- Use the **UP** and **DOWN** buttons to select the counter you wish to reset.
- Press the **UP** and **DOWN** buttons for five seconds
- Hold the **UP** button to deselect the counters.

Pages **E.04, E.05, E.06, E.07, E.08, E.09, E.10** (CANBUS 1 ... 6) (available only if the CANBUS configuration has been activated) show the measurements acquired via CANBUS.

 **INFORMATION!** The displayed values depend on the ECU model.

Page **E.11 (MAINTENANCE)** (available only if the output for fuel pump management is configured) contains the information and commands relating to the fuel pump.

This page contains the counter   of the hours left for maintenance (managed by the controller, it cannot be cleared).

Pages **E.12-13-14-15** (EXHAUST GAS TREATMENT) display the icons and measurements acquired by the ECU, concerning the treatment of exhaust gases. The information and icons shown comply with the TIER 4 / STAGE 5 standard.

Pages **E.16-17-18-19-20-21** are pages enabled in the ECU configuration files. Through these files it is possible to create customized pages showing specific measurements (not adhering to the J1939 standard), specific to that ECU.

6.5.5 HISTORY LOGS (H.XX)





This mode allows displaying events and data records.

The historical archives are accessible only from the navigation menu between the modes.

To enter the archives view, after selecting the ARCHIVES icon  (MAIN MENU), keep the **DOWN** button pressed until the basic page of the HISTORY LOGS is displayed (H.03).

Each recording is identified by a number and by the date and time of storage. The number is shown in the first line on the multifunctional display, together with the total number of records recorded.

At the start of the procedure, the list of the available archive is displayed. Four types of archives are managed:

#	Description	Icon	ID:	Max
1	Events		H.09	64
2	Fast Analogues		H.15	64
3	Slow Analogues		H.21	42
4	Engine-DTC		H.27	16

The different pages can be scrolled using the **UP** and **DOWN** buttons.

Keep the **DOWN** button pressed: the selected archive is activated (the one highlighted in reverse). Hold the **UP** button to return to the "H.03" page.

If you are in a mode that limits the use of the vertical scroll buttons, it may be necessary to press and hold the **UP** button one or more times.

7 Operating principles

7.1 Plant types

7.1.1 SSB

The following are the components of a standard emergency system consisting of a public power line ("mains"), a "load" line (the utility you want to power), a "generator" line (generator set with composed by a thermal engine and an alternator), a control panel with inside:

- An MCB circuit breaker for the management of the mains.
- A GCB circuit breaker for the management of the generator.
- The GC250 device for controlling the engine and the electrical lines involved.
- Speed and voltage regulators.
- Current transformers.
- A battery charger.
- A series of components for the management of the auxiliary services (relays, fuses, terminals, etc.).

The switching of the loads between the mains and the generator (and vice versa), is carried out by contactors, mechanically and electrically interlocked, powered by their related lines but opened/closed by the controller.

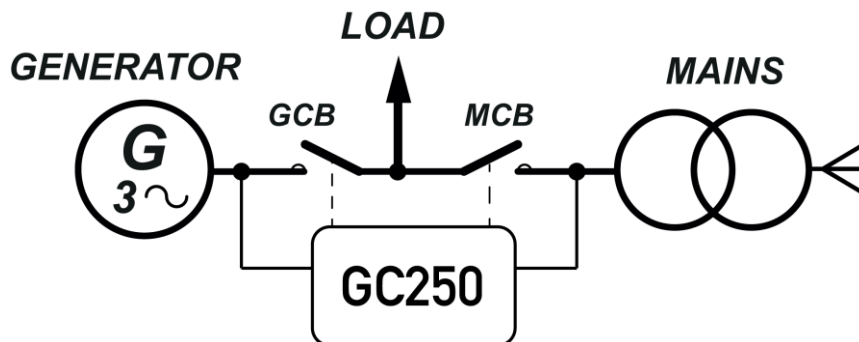

7.1.2 SPM

The following are the components of an "island" system consisting of a "loads" line (the utility you want to feed), a "generator" line (generator set with composed by a thermal engine and an alternator), and a control panel with inside:

- A GCB circuit breaker for the management of the generator.
- The GC250 device for controlling the engine and the electrical lines involved.
- Speed and voltage regulators.
- Current transformers.
- A battery charger.
- A series of components for the management of the auxiliary services (relays, fuses, terminals, etc.).

The connection/disconnection of the loads to the generator is carried out by the GCB contactor, powered by the generator's lines, opened/closed by the controller.

In **AUTO** mode, and with a digital input properly configured as "start inhibition", the start-up sequence, the management of the circuit breaker and the stop sequence are determined by the state of the "start inhibition" input and managed independently by the controller.

In **MAN** mode, the engine is started and stopped by the operator using the **START** and **STOP** buttons.

i **INFORMATION!** In **MAN** mode, the generator switching management is available only through a properly configured digital input.

If there are no GCB switching management sequences in the system configuration to power the "User" line, we recommend preferring the **AUTO** mode with the "start inhibition" digital input.

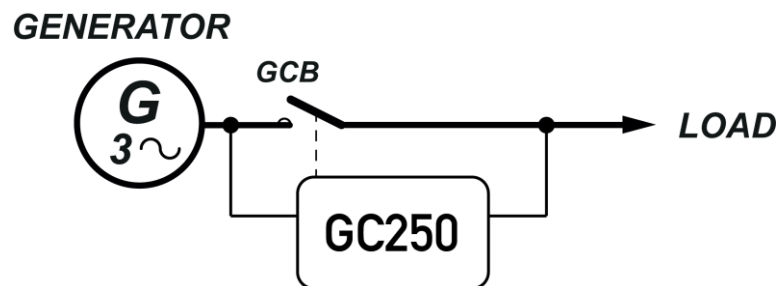

7.2 Operating modes



INFORMATION! The MCB circuit breaker is provided only for SSB (Single Stand-By).

7.2.1 Off/Reset



Lamp fixed on.

In this mode, the loads are usually powered by the mains with the MCB circuit breaker closed. MCB is supplied by the mains itself, so it stays closed as long as the mains is present. In case of mains failure, the loads will be disconnected from the mains, but the generator will not be started. The protections on mains and on the engine are disabled.

7.2.2 Automatic



Lamp fixed on.

In AUTO mode, the main task of the controller is to ensure the loads are powered. To fulfil this task, the controller continuously monitors the mains for voltage/frequency anomalies, wrong phase's sequence or voltage unbalance.

- **Mains present:** as long as the voltage and the frequency of the mains are inside the configured thresholds, the MCB circuit breaker is closed and the loads are powered by the mains. The generator set is not activated and the GCB circuit breaker is open.
- **Mains failure:** as soon as the voltage and the frequency of the mains are outside the configured thresholds (and thus the loads are unsupplied or supplied with wrong voltages), the controller will start the generator start-up sequence.
 1. Engine start command: the controller opens the fuel solenoid, enable the ECU and the governors and cranks the engine (commands can be sent to the ECU over the CANBUS J1939 link). An alarm is activated if the engine won't start after the maximum number of start attempts established by the configured parameters).
 2. The controller waits for the stable operating conditions of the generator by monitoring voltage/frequency. An alarm is activated if operating conditions are not reached after the configured time.
 3. The controller opens MCB and closes GCB, connecting the loads to the generator.
 4. The generator supplies the loads, while the controller constantly monitors the electrical measurements of the mains and of the generator and the analogue measurement of the engine (to protect the whole plant), waiting for the mains to become available again.
- **Delay for mains in threshold:** the loads are supplied by the generator through GCB (MCB is open), the mains is back in tolerance after a failure. If the mains voltage/frequency are in tolerance, the controller will start this sequence:
 1. The controller opens GCB and closes MCB, connecting the loads to the mains.



WARNING! Switching between MCB and GCB or vice versa creates a black out on the loads line. The loads will remain disconnected for the minimum time necessary to ensure correct contactor switching.

2. The generating set is kept running for cooling purpose. Once the cooling cycle is finished, the controller closes the fuel solenoid and sends a stop command to the ECU (even through CANBUS J1939). The ECU and the governors are disabled
3. The loads are powered by the mains through the MCB. The generator is stopped with the GCB open, ready for a possible new intervention.

 **INFORMATION!** The operating sequence described above is generic and, in some cases, may not correspond to that implemented in your system. For more information contact your installer or the manufacturer.

7.2.3 Manual

 **INFORMATION!** In the MAN mode, the management of the switching between the mains and the generator is only available through a properly configured digital input. If this input has not been configured, we recommend preferring the AUTO mode.



Lamp fixed on.

In this mode, the loads are usually powered by the mains through the MCB contactor. MCB is supplied by the mains itself, so it stays closed as long as the mains is present. In case of mains failure, the operator has to start the generator set and manage the changeover to ensure energy supply to the loads.

7.2.3.1 Circuit breaker management without external input

- 1) Press the **START** button, and hold it down until the engine starts.
- 2) Press and hold the **AUTO** button to activate the **AUTO** mode.
- 3) From this moment, all the sequences will be performed automatically by the controller: the switching of the loads on the generator and on the mains, the cooling of the engine and the final stopping of the engine.
- 4) At the end of all the sequences it is necessary to press the **STOP** button to exit the **AUTO** mode and activate the **OFF/RESET** mode.



WARNING! Switching between MCB and GCB or vice versa creates a black out on the loads line. The loads will remain disconnected for the minimum time necessary to ensure correct contactor switching.

7.2.3.2 Circuit breaker management with external input

- 1) Press the **START** button, and hold it down until the engine starts.
- 2) Deactivate the "MCB closure" digital input.
- 3) Activate the digital input "GCB closure".

The loads are now powered by the generator.

When the mains returns after the black (which can be verified by the fixed icon of the mains  on the screen M.01, it is possible to switch the loads from the generator to the mains by the previously described digital inputs. This operation is up to the operator.

Manual engine stopping sequence:

- 1) Check for the return of the mains on page M.01. The mains symbol must be lit steadily.

- 2) Deactivate the "GCB closure" digital input.
- 3) Activate the "MCB closure" digital input.
- 4) To stop the engine, press the STOP button.

 **WARNING!** Switching between MCB and GCB or vice versa creates a black out on the loads line. The loads will remain disconnected for the minimum time necessary to ensure correct contactor switching.

 **INFORMATION!** It is advisable, after switching the loads to the mains, not to immediately stop the engine, but to leave it running until properly cooled.

7.2.4 TEST

The **TEST** sequence has the only purpose of testing the start-up of the generating set, so as to verify its operation in anticipation of a possible emergency situation (for example a mains failure) and to keep its mechanical parts periodically lubricated and efficient.

The **TEST** sequence can be planned and periodically executed automatically by the controller with a calendar programming. To allow activation of the properly programmed TEST sequence, the device must be in AUTO mode.

- 1) Engine start command: the controller opens the fuel solenoid, enable the ECU and the governors and cranks the engine (commands can be sent to the ECU over the CANBUS J1939 link). An alarm is activated if the engine won't start after the maximum number of start attempts established by the configured parameters).
- 2) In the display page M.01, the generator symbol  fixed on will indicate the correct voltage/frequency of the generator.
- 3) The engine will remain running, without switching between the MCB and GCB contactors.
- 4) By pressing the **STOP** button during the test, an alarm is activated which prevents the engine from restarting, which can only be reset by going to **OFF/RESET** mode.
- 5) The **AUTO** light will remain fixed and the engine will be stopped, stopping is commanded by opening the fuel solenoid valve and / or command on the actuator.

 **INFORMATION!** if during the TEST phase an anomaly occurs on the mains that causes the automatic intervention of the generator, the operating mode switches automatically from TEST to AUTO. When the mains returns, the mode will remain AUTO.

Usually the **TEST** sequence does not require the load transfer from the mains to the generator, in order not to create a useless blackout on the loads.

 **INFORMATION!** The operating sequence described above is generic and, in some cases, may not correspond to that implemented in your system. For more information contact your installer or the manufacturer.

8 Date/time setting

The device includes a clock/calendar used mainly for the following functions:

- Weekly working planning for the generator.
- Weekly TEST planning for the generator.
- Recording of events with date and time in historical archives.

The setting of the date/time is possible in the PROGRAM menu, which can only be activated from the **OFF/RESET** mode, by means of the **STOP+AUTO** buttons.

To update the date/time of the controller, access the menu "**4.7.1 Date - Time**". Use the **UP** and **DOWN** buttons to move between the submenus and use the **AUTO** button to enter the submenu. The complete path to the date/time programming page is: **PROGRAM → 4 AUXILIARY FUNCTIONS → 4.7 Device → 4.7.1 Date-Time**.

Press the **AUTO** button to display the six parameters dedicated to the date/time. To move between the parameters and/or change their values, use the **UP** and **DOWN** buttons; the **AUTO** button is used to confirm the value while the **STOP** button aborts the change.

If the values are between <...> it means that you do not have the access rights to modify the parameters. See paragraph 6.5.1.1 to activate authentication for the USER level.

To return to the initial menu, press the **STOP** button many times.

9 Fuel pump (if present)

The controller implements a complete management of the fuel pump, for loading the daily tank from the storage tank. Pump management includes automatic and manual controls, accessible from the front panel.



9.1 Operating selection

From any operating modes of the controller, press the **UP** button (for at least 1 second) to

activate the main menu. Select the "ENGINE" pages . Press the **DOWN** button (for at least 1 second) to enter the "ENGINE" pages. Navigate between the E.XX pages with the **UP** and **DOWN** buttons up to the E.10 (FUEL PUMP) page.

From here it is possible to select the pump control mode. Press and hold the **DOWN** button to enable the selection of the fuel pump operating mode (reverse display). Use the **UP** and **DOWN** buttons to select the desired mode. Confirm the mode by keeping the **UP** button pressed, or cancel the change by pressing **DOWN**.

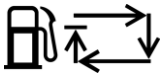
The available modes are:

-  AUTO: the pump is automatically activated when the "start level" threshold or contact is reached and it is stopped stops when the "stop level" threshold or contact is reached.
-  MAN-ON: the pump is activated when the fuel drops below the "maximum level" threshold or contact and is deactivated when it exceeds it, keeping the level always constant.

-  MAN-OFF: the pump is always stopped.

When the controller is in OFF/RESET mode, the pump is always stopped.

 **INFORMATION!** with fuel pump warning activated, the fuel pump operating mode is automatically set to **MAN-OFF**.

10 Energy saving

This function, especially useful in SPM (Single Prime Mover) applications, reduces the energy consumption of the controller to the essential, so as to limit the discharge of the starter battery to a minimum when the generator set is stopped. The function will be activated automatically by setting a value other than 0 in parameter P.0590 (value in minutes). Once the set time has elapsed, the controller will deactivate the LCD display and the lamps, only if the following conditions are met:

- **OFF/RESET** operating mode.
- Engine stopped.
- Emergency Stop button activated.
- USB communications not running.
- Digital oil pressure input (active when the engine is stopped), if used, configured and connected to terminal T.16.

It is possible to manually activate the function, provided that the conditions described above are verified, by holding the **STOP** button for at least 5 seconds.

To exit this mode, simply press the **START** button.

**This document is owned by SICES s.r.l.. All rights reserved.
All rights reserved. SICES s.r.l. reserves the right to modify this document without prior notice.
SICES has made any effort to ensure that the information herein provide are correct; in any case
SICES does not assume any liability for the use this information.
The disclosure by any means of this document to third parties is not allowed.**

S.I.C.E.S. SRL
Società Italiana Costruzioni Elettriche Sumirago

Via Molinello 8B
21040 - Jerago con Orago (VA) ITALY

T +39 0331 212941
F +39 0331 216102

www.sices.eu
sales@sices.eu

